



APPROVED MINUTES

September 16, 2021 Standards Committee Meeting

October 28, 2021

TO: Standards Committee

FROM: Scott Trammell, Secretary

RE: Minutes from the September 16, 2021 Standards Committee Meeting

The Standards Committee meeting was called to order by Mr. Pankow, Chair, at 09:03 a.m. on September 16, 2021, and was held virtually via *Teams* (Microsoft application). The meeting was adjourned at 11:10 a.m.

The following committee members were in attendance:

Gregory Pankow, Chairman, Director, Construction Management
John Wooden, Contract Administration Division
Dave Boruff, Traffic Engineering
Peter White, Bridge Engineering
Joseph Novak, Construction Management
Kumar Dave, Pavement Engineering
Jim Reilman, Materials and Tests
Michael Koch, District Construction, Fort Wayne District
Mark Orton, Highway Engineering
Kurt Pelz, Construction Technical Support
Louis Feagans, Engineering and Asset Management

Also, presence was captured by *Microsoft Teams* of the following:

Awwad, Nathan, INDOT
Bazlamit, Subhi, INDOT
Blanchard, Jacob, INDOT
Camarata, Rebecca, INDOT
Duncan, Thomas, FHWA

Osborn, Dan, ICI
Patterson, Patrick, INDOT
Podorvanova, Lana, INDOT
Ritter, John, INDOT
Smutzer, Katherine, INDOT

Susong, John, guest
Fisher, Steve, INDOT
Weaver, Crystal, INDOT
Mueller, Bart, INDOT
Berk, Jennifer, INDOT
Couch, Gregory, INDOT
Chernet, Martha, INDOT
Kachler, Mischa, INDOT
Keefer, Diane, INDOT
Leckie, John, guest
Siddiki, Nayyar, INDOT

Stickney, Daniel, INDOT
Trammell, Scott, INDOT
Barney, Bruce, INDOT
Bowen, Alisa, INDOT
Bruno, Joseph, INDOT
Harris, Tom, INDOT
Hauser, Derrick, INDOT
Coulter Josh, guest
Pfeiffer, Nate, INDOT
Slaymon, Shawn, INDOT
Pressler, Corey, INDOT

The following items were discussed:

A. GENERAL BUSINESS ITEMS

OLD BUSINESS (No items were listed)

NEW BUSINESS

1. *Approval of the Minutes from the August 19, 2021 meeting*

Mr. Pankow requested a motion to approve the Minutes from the August 19, 2021 meeting.

Motion: Mr. Novak
Second: Mr. Boruff
Ayes: - 8
Nays: - 0
Absent: - 2

ACTION:

PASSED AS SUBMITTED

B. CONCEPTUAL PROPOSAL ITEMS

OLD BUSINESS (No items were listed)

NEW BUSINESS (No items were listed)

C. STANDARD SPECIFICATIONS, SPECIAL PROVISIONS AND STANDARD DRAWINGS PROPOSED ITEMS

OLD BUSINESS

[Item No. 5 \(2/18/2021\)](#) [Mr. Boruff](#) [pg 5](#)

Standard Drawings:

E 801-TCTC series (see proposal)

E 801-TCMO series (see proposal)

E 801-TCFO series (see proposal)

ACTION: WITHDRAWN

NEW BUSINESS

[Item No. 1 \(2022 SS\)](#) [Mr. Pelz](#) [pg 30](#)

Special Provision:

801-R-672 LAW ENFORCEMENT OFFICER FOR WORK ZONE SAFETY

ACTION: PASSED AS REVISED

[Item No. 2 \(2022 SS\)](#) [Mr. Reilman](#) [pg 43](#)

Special Provision:

214-R-733 GEOSYNTHETICS

ACTION: PASSED AS SUBMITTED

[Item No. 3 \(2022 SS\)](#) [Mr. Wooden](#) [pg 51](#)

Special Provision:

xxx-x-xxx *TEMPORARY CURB RAMP*

ACTION: WITHDRAWN

[Item No. 4 \(2022 SS\)](#) [Mr. Wooden](#) [pg 56](#)

Special Provision:

xxx-x-xxx *TEMPORARY SHORING*

ACTION: WITHDRAWN

[Item No. 5 \(2022 SS\)](#) [Mr. Wooden](#) [pg 60](#)

Special Provision:

xxx-x-xxx

TEMPORARY WORKSITE SPEED DISPLAY

ACTION:

WITHDRAWN

[Item No. 6 \(2022 SS\)](#) [Mr. Wooden](#) [pg 65](#)

Special Provision:

xxx-x-xxx

*WATERPROOFING MEMBRANE FOR
REINFORCED-CONCRETE BOX STRUCTURES
AND THREE-SIDED STRUCTURES*

ACTION:

WITHDRAWN

[Item No. 7 \(2022 SS\)](#) [Mr. Wooden](#) [pg 75](#)

Special Provision:

xxx-x-xxx

CURED-IN-PLACE PIPE LINER, CIPP

ACTION:

PASSED AS SUBMITTED

[Item No. 8 \(2022 SS\)](#) [Mr. Wooden](#) [pg 83](#)

Special Provision:

xxx-x-xxx

*HEADWALLS, WINGWALLS, AND FOOTINGS
CONSTRUCTION ON AN EXISTING STRUCTURES*

ACTION:

PASSED AS REVISED

[Item No. 9 \(2022 SS\)](#) [Mr. Wooden](#) [pg 88](#)

Special Provision:

107-x-xxx

MIGRATORY BIRD PROTECTION

ACTION:

PASSED AS SUBMITTED

[Item No. 10 \(2022 SS\)](#) [Mr. Wooden](#) [pg 94](#)

Special Provision:

xxx-x-xxx

PUMP AROUND

ACTION:

PASSED AS REVISED

cc: Committee Members
FHWA
ICI

STANDARD SPECIFICATIONS, SPECIAL PROVISIONS AND STANDARD DRAWINGS
REVISION TO STANDARD DRAWINGS

PROPOSAL TO STANDARDS COMMITTEE

PROBLEM(S) ENCOUNTERED: The Standard Drawing series for flagger operations (E 801-TCFO) largely date back to 1997 and include details for work that does not include flagging. INDOT Standard Drawings E 801-TCFO-03, E 801-TCTC-09, and E 801-TCTC-10 depict mobile operations and should be combined into a new series just for mobile operations. Other sheets in the temporary closure series (801-TCTC) are duplicates of other drawings or show information that should be detailed in the plans.

PROPOSED SOLUTION: Revise and update the standard drawing series on flagger operations (E 801-TCFO) and create a new series for mobile operations (E 801-TCMO). Delete unnecessary and duplicate details from the temporary closure series (E 801-TCTC).

APPLICABLE STANDARD SPECIFICATIONS: 801.16 was updated at the 2/18/21 meeting

APPLICABLE STANDARD DRAWINGS: 2 series [E 801-TCFO and E 801-TCTC]

<u>Proposed New (3)</u>	<u>Proposed Deletions (6)</u>		<u>Proposed Moves (3)</u>
801-TCFO-01 Flagger Operations Index	801-TCFO-05	801-TCTC-06	801-TCFO-03 to 801-TCMO-02
801-TCFO-03 Flagger Operations < 50 mph	801-TCFO-06	801-TCTC-07	801-TCTC-09 to 801-TCMO-03
801-TCMO-01 Mobile Operations Index	801-TCTC-05	801-TCTC-08	801-TCTC-10 to 801-TCMO-04

APPLICABLE DESIGN MANUAL SECTION: No

APPLICABLE SECTION OF GIFE: No

APPLICABLE RECURRING SPECIAL PROVISIONS: 801-T-209

PAY ITEMS AFFECTED: No

APPLICABLE SUB-COMMITTEE ENDORSEMENT: Yes, traffic standards subcommittee

IF APPROVED AS RSP OR RPD, PROPOSED BASIS FOR USE: N/A

IMPACT ANALYSIS (attach report): Yes, attached

Submitted By: Joe Bruno on behalf of Dave Boruff
Title: Sr. Engineer of Signals & Markings
Organization: INDOT Traffic Engineering Division
Phone Number: (317) 234-7949

Date: 8/23/2021

STANDARD SPECIFICATIONS, SPECIAL PROVISIONS AND STANDARD DRAWINGS
REVISION TO STANDARD DRAWINGS

IMPACT ANALYSIS REPORT CHECKLIST

Explain the business case as to why this item should be presented to the Standards Committee for approval. Answer the following questions with Yes, No or N/A.

Does this item appear in any other specification sections? Yes

Will approval of this item affect the Approved Materials List? No

Will this proposal improve:

Construction costs? No

Construction time? No

Customer satisfaction? Yes

Congestion/travel time? No

Ride quality? No

Will this proposal reduce operational costs or maintenance effort? No

Will this item improve safety:

For motorists? Yes

For construction workers? Yes

Will this proposal improve quality for:

Construction procedures/processes? Yes

Asset preservation? Yes

Design process? No

Will this change provide the contractor more flexibility? No

Will this proposal provide clarification for the Contractor and field personnel? Yes

Can this item improve/reduce the number of potential change orders? Yes

Is this proposal needed for compliance with:

Federal or State regulations? No

AASHTO or other design code? No

Is this item editorial? No

Provide any further information as to why this proposal should be placed on the Standards Committee meeting Agenda: N/A

REVISION TO STANDARD DRAWINGS

E 801-TCFO-01 FLAGGER OPERATIONS (WITH MARKUPS)

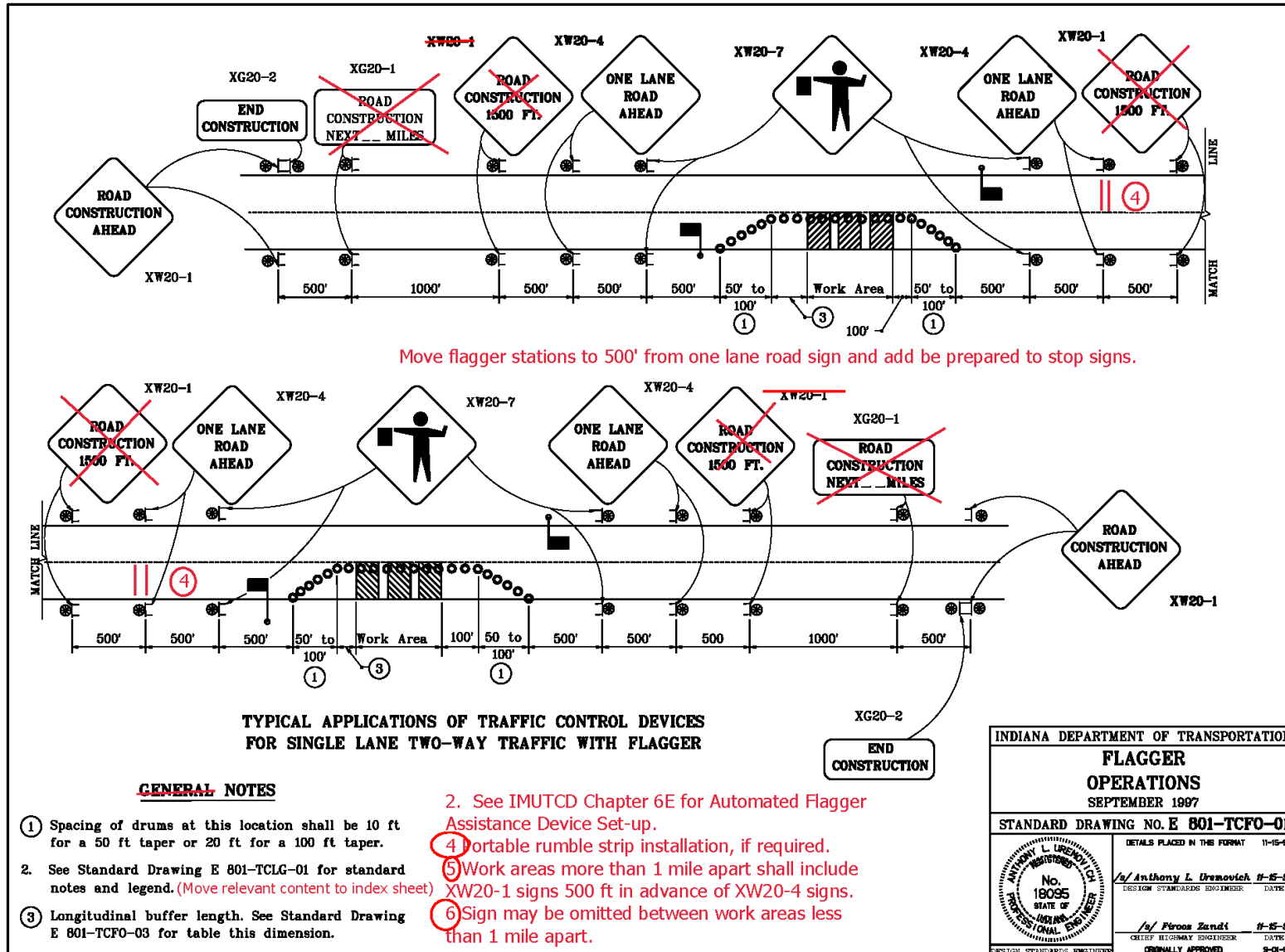

REVISION TO STANDARD DRAWINGS

E 801-TCFO-02 MAINTENANCE OF TRAFFIC FOR MOVING OPERATIONS (WITH MARKUPS)

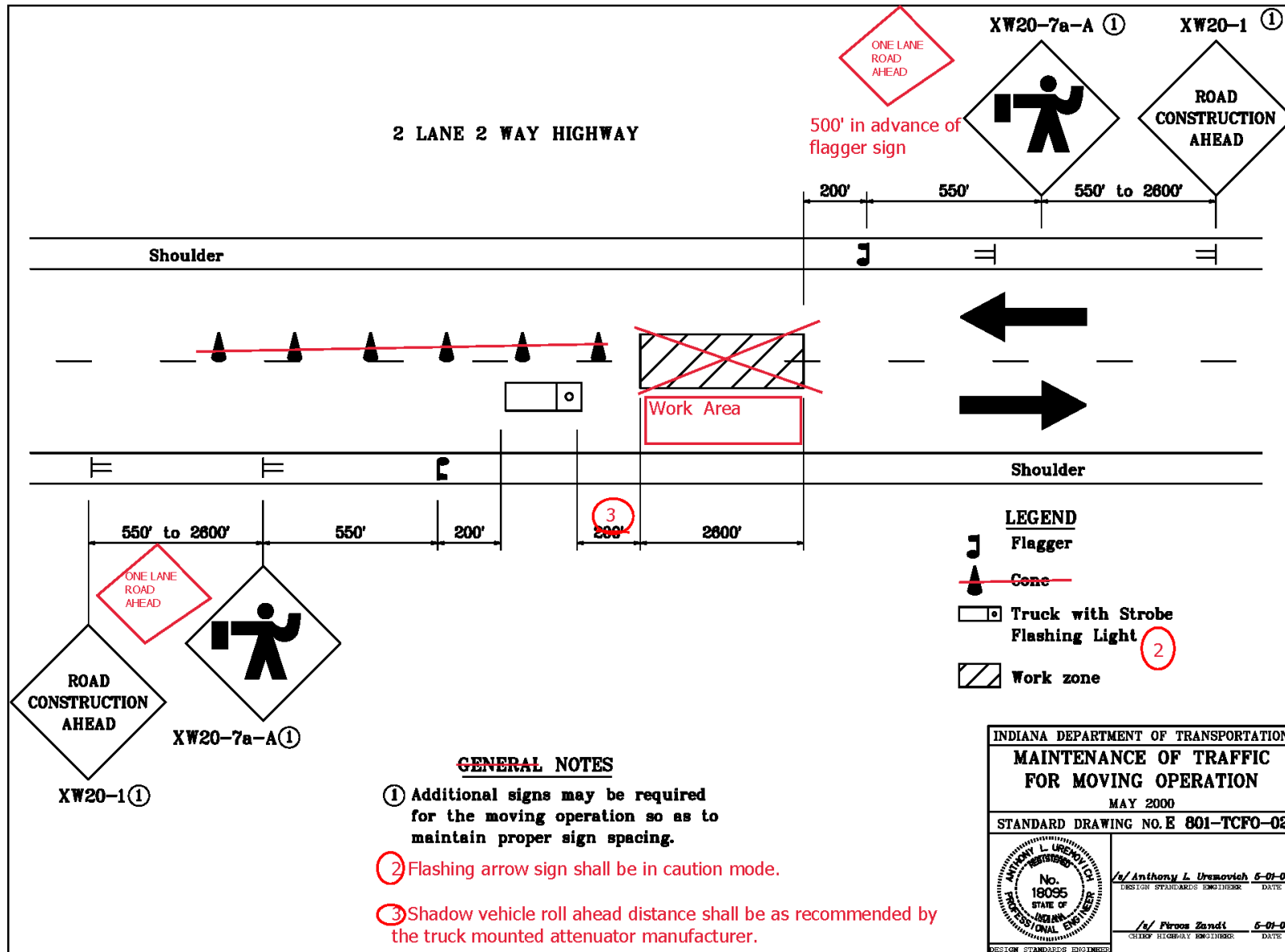

REVISION TO STANDARD DRAWINGS

E 801-TCFO-03 MAINTENANCE OF TRAFFIC FOR REFLECTOR REPLACEMENT (WITH MARKUPS)

Create New Sheet for Flagging Operations Similar to IMUTCD Figure 6H-10

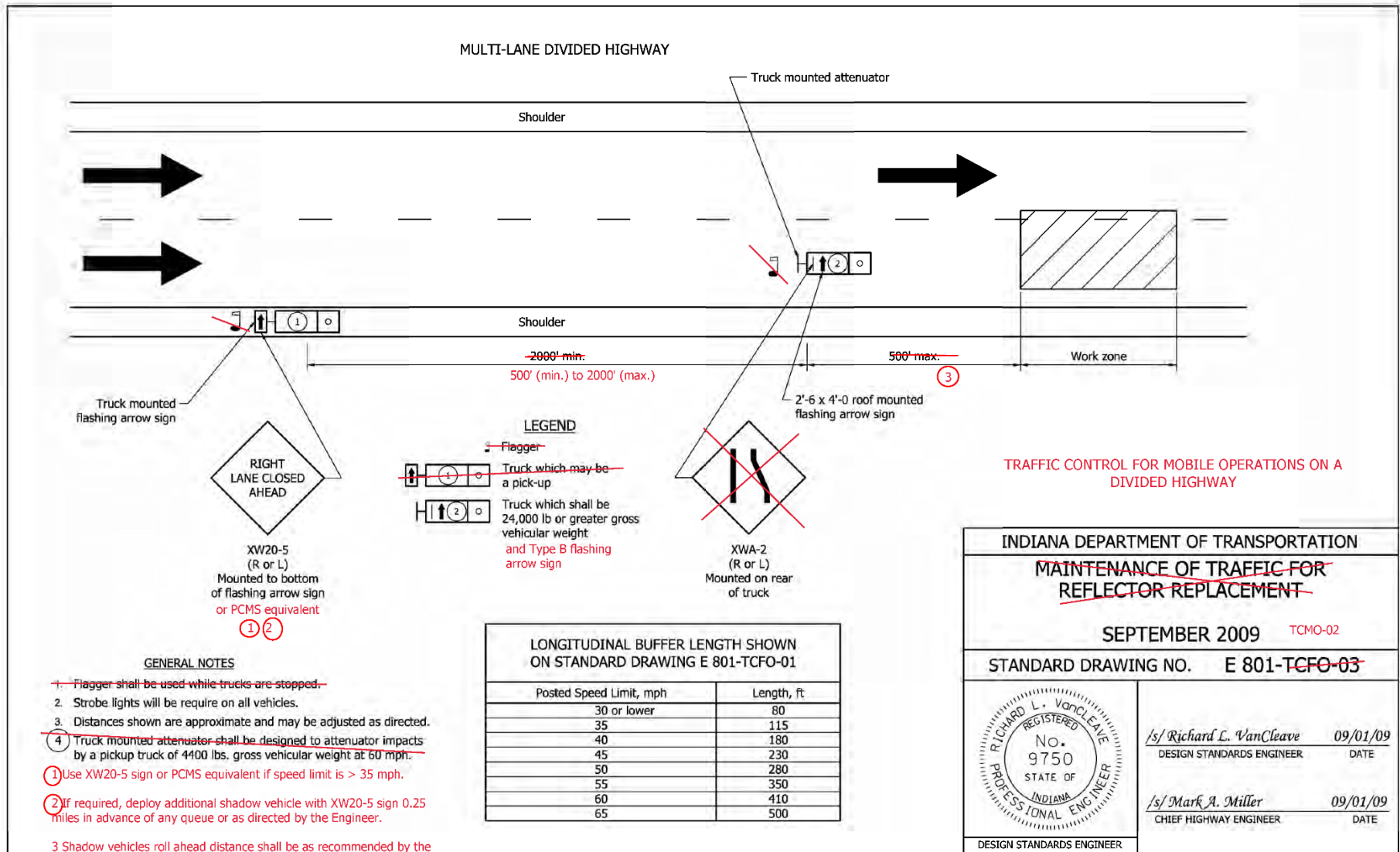

REVISION TO STANDARD DRAWINGS

E 801-TCFO-04 TRAFFIC CONTROL FOR OVERHEAD SIGN INSTALLATION (WITH MARKUPS)

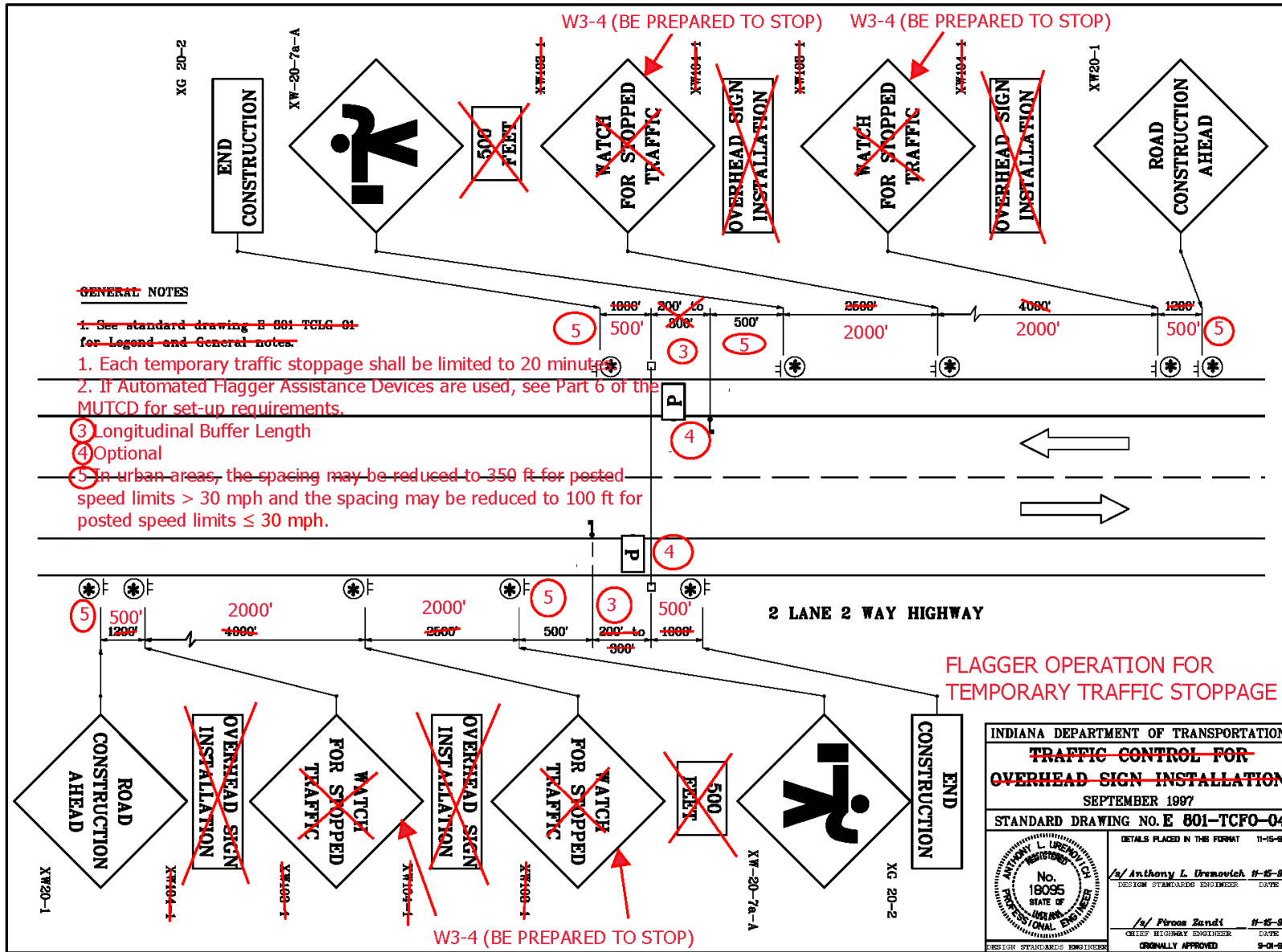

INDIANA DEPARTMENT OF TRANSPORTATION	
TRAFFIC CONTROL FOR	
OVERHEAD SIGN INSTALLATION	
SEPTEMBER 1997	
STANDARD DRAWING NO. E 801-TCFO-04	
DETAILS PLACED IN THE FORMAT	11-15-98
	/s/ Anthony L. Dremovich #15-89 DESIGN STANDARDS ENGINEER DATE
	/s/ Piroos Zandi #15-89 CHIEF HIGHWAY ENGINEER DATE
DESIGN STANDARDS ENGINEER	ORIGINALLY APPROVED 9-01-97

REVISION TO STANDARD DRAWINGS

E 801-TCFO-05 TRAFFIC CONTROL FOR OVERHEAD INSTALLATION (WITH MARKUPS)

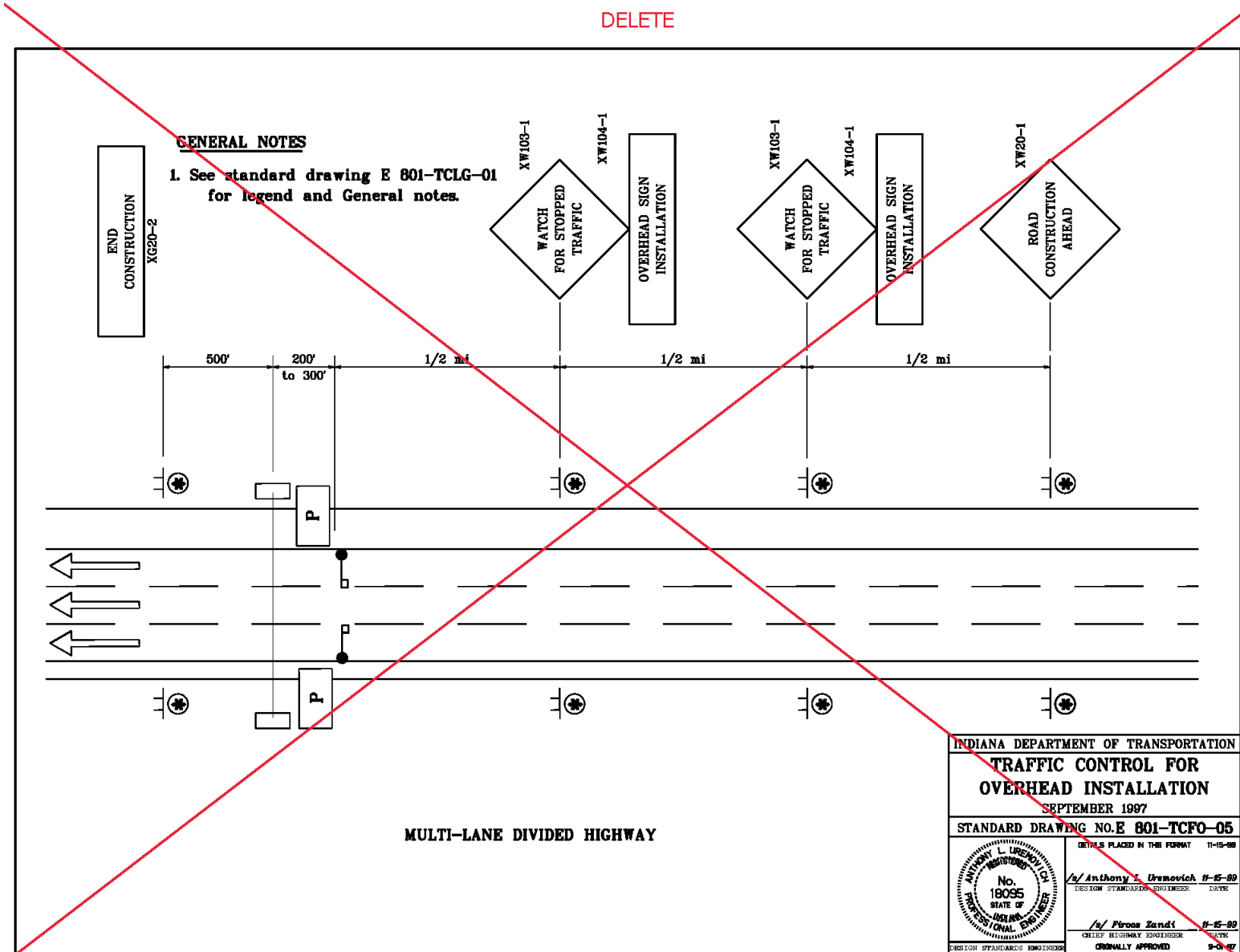

REVISION TO STANDARD DRAWINGS

E 801-TCFO-06 TRAFFIC CONTROL FOR INTERSECTION WORK (WITH MARKUPS)

DELETE

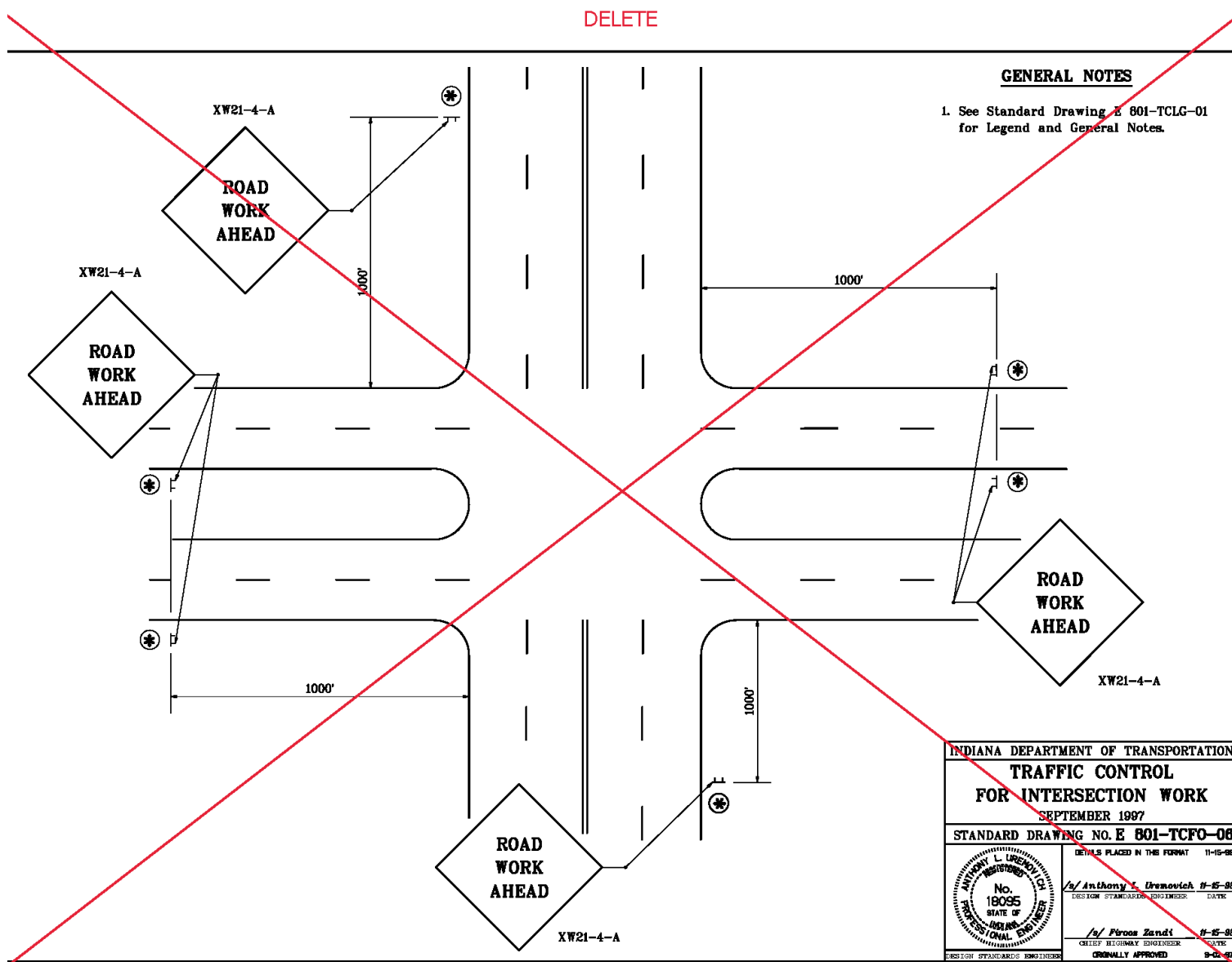

REVISION TO STANDARD DRAWINGS

E 801-TCTC-05 TRAFFIC CONTROL FOR DAYTIME LANE CLOSURE (WITH MARKUPS)

Delete (Addressed in 801-TCFO Series)

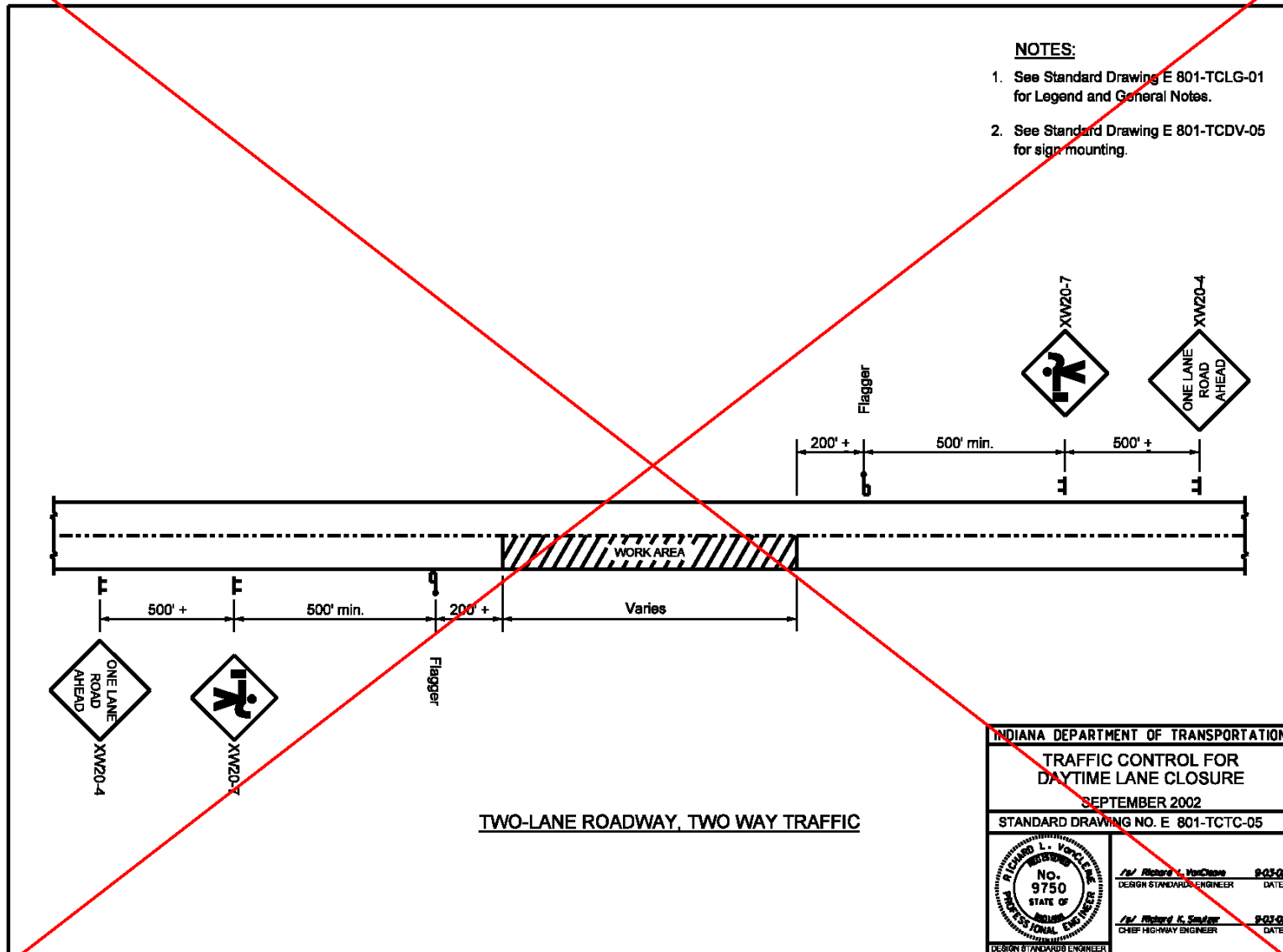

REVISION TO STANDARD DRAWINGS

E 801-TCTC-06 MAINTENANCE OF TRAFFIC FOR RPM CASTING INSTALLATION (WITH MARKUPS)

(Duplicate of 801-TCFO-03)

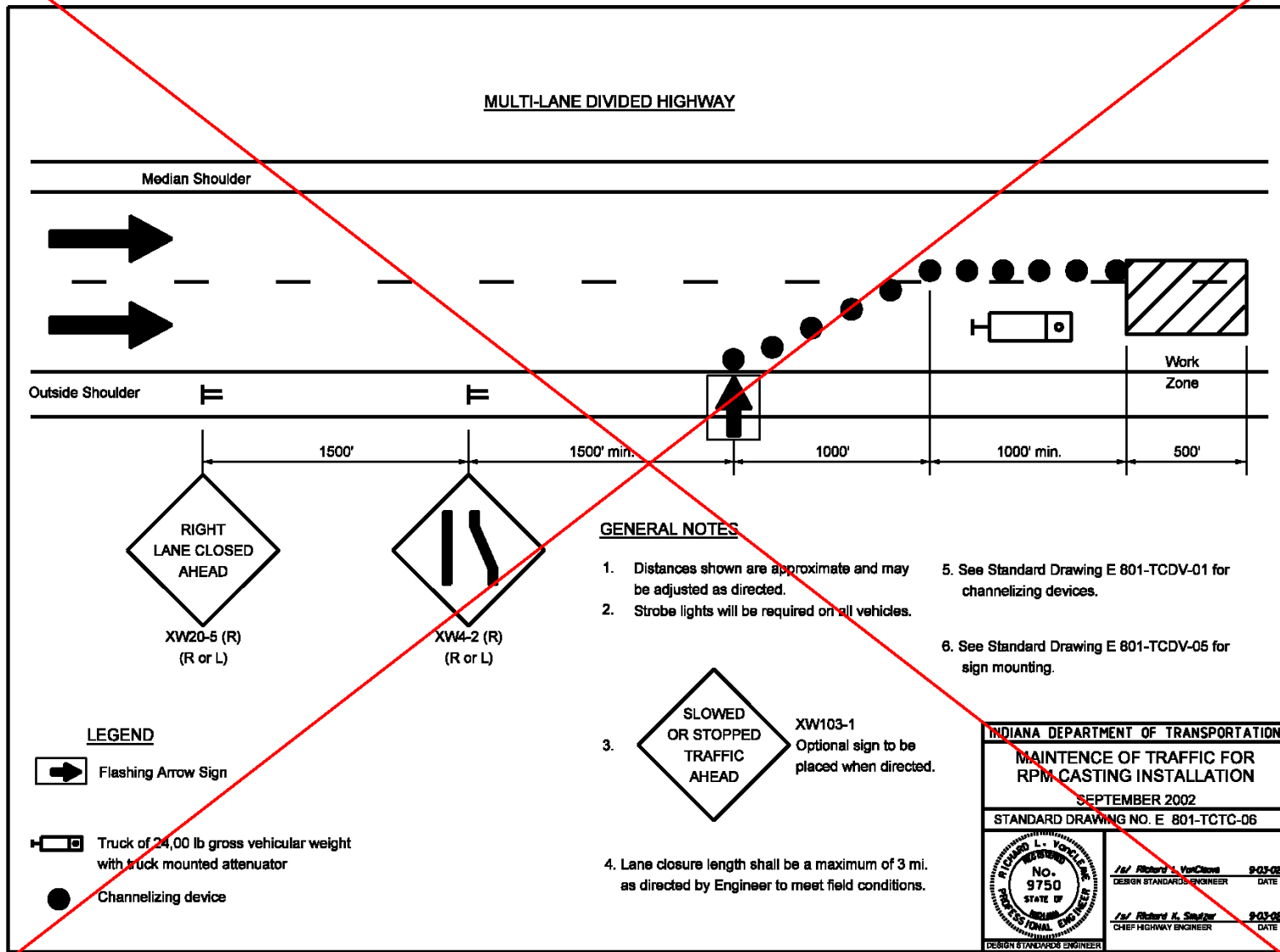

REVISION TO STANDARD DRAWINGS

E 801-TCTC-07 MAINTENANCE OF TRAFFIC FOR RPM CASTING REPLACEMENT (WITH MARKUPS)

(Addressed in 801-TCLC-15)

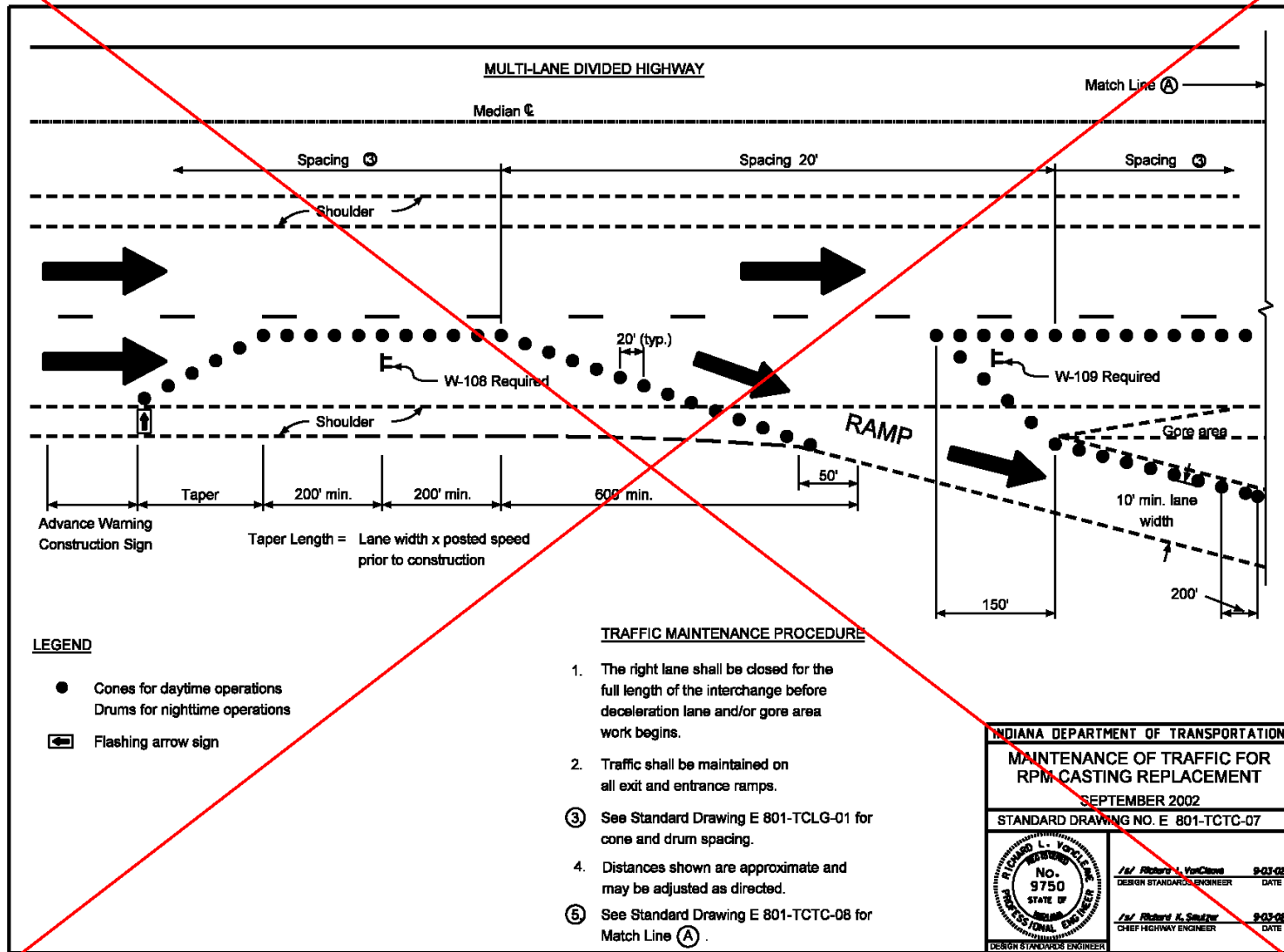

REVISION TO STANDARD DRAWINGS

E 801-TCTC-08 MAINTENANCE OF TRAFFIC FOR RPM CASTING REPLACEMENT (WITH MARKUPS)

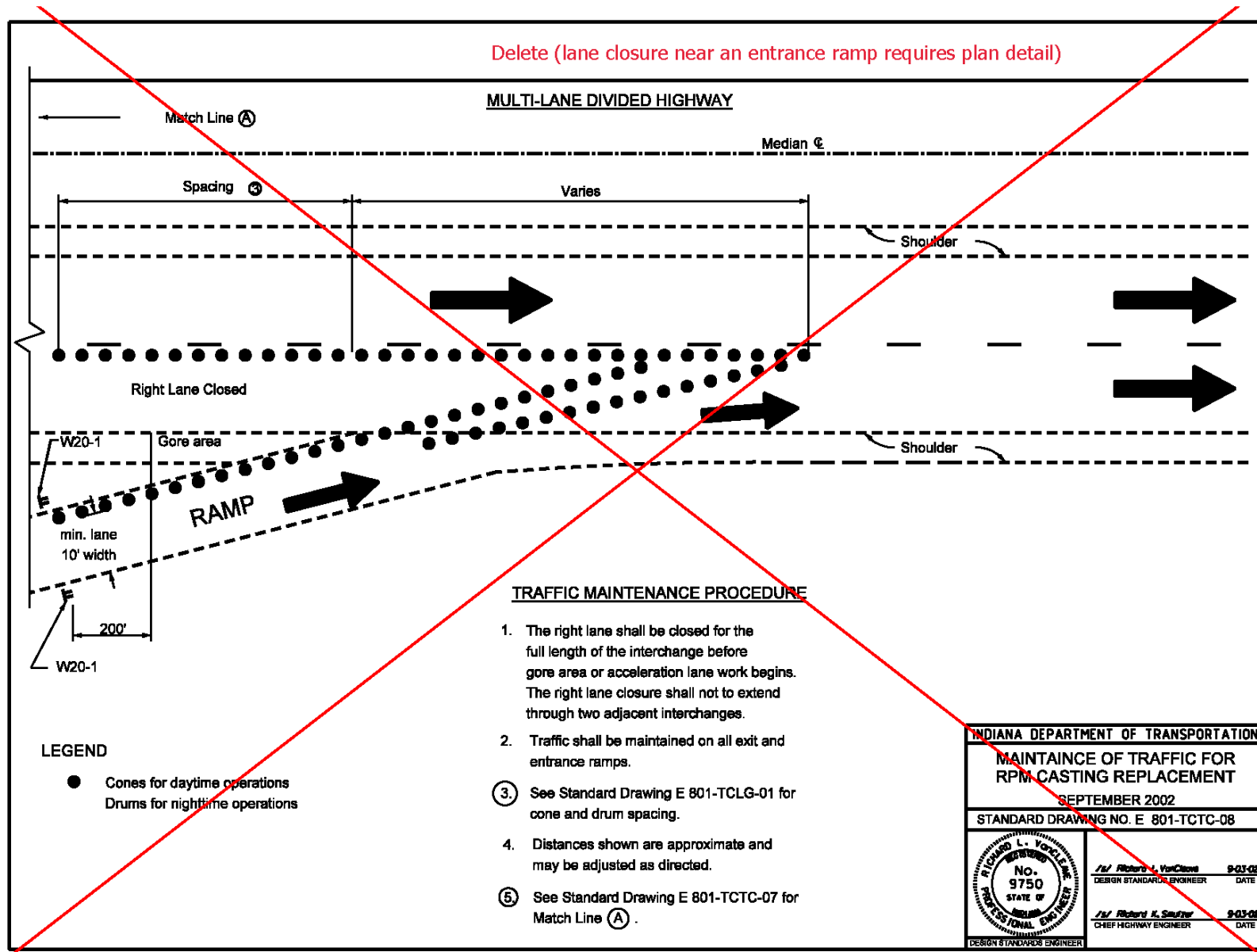

REVISION TO STANDARD DRAWINGS

E 801-TCTC-09 MAINTENANCE OF TRAFFIC FOR RPM REFLECTOR REPLACEMENT (WITH MARKUPS)

Move to New Series on Traffic Control for Mobile Operations

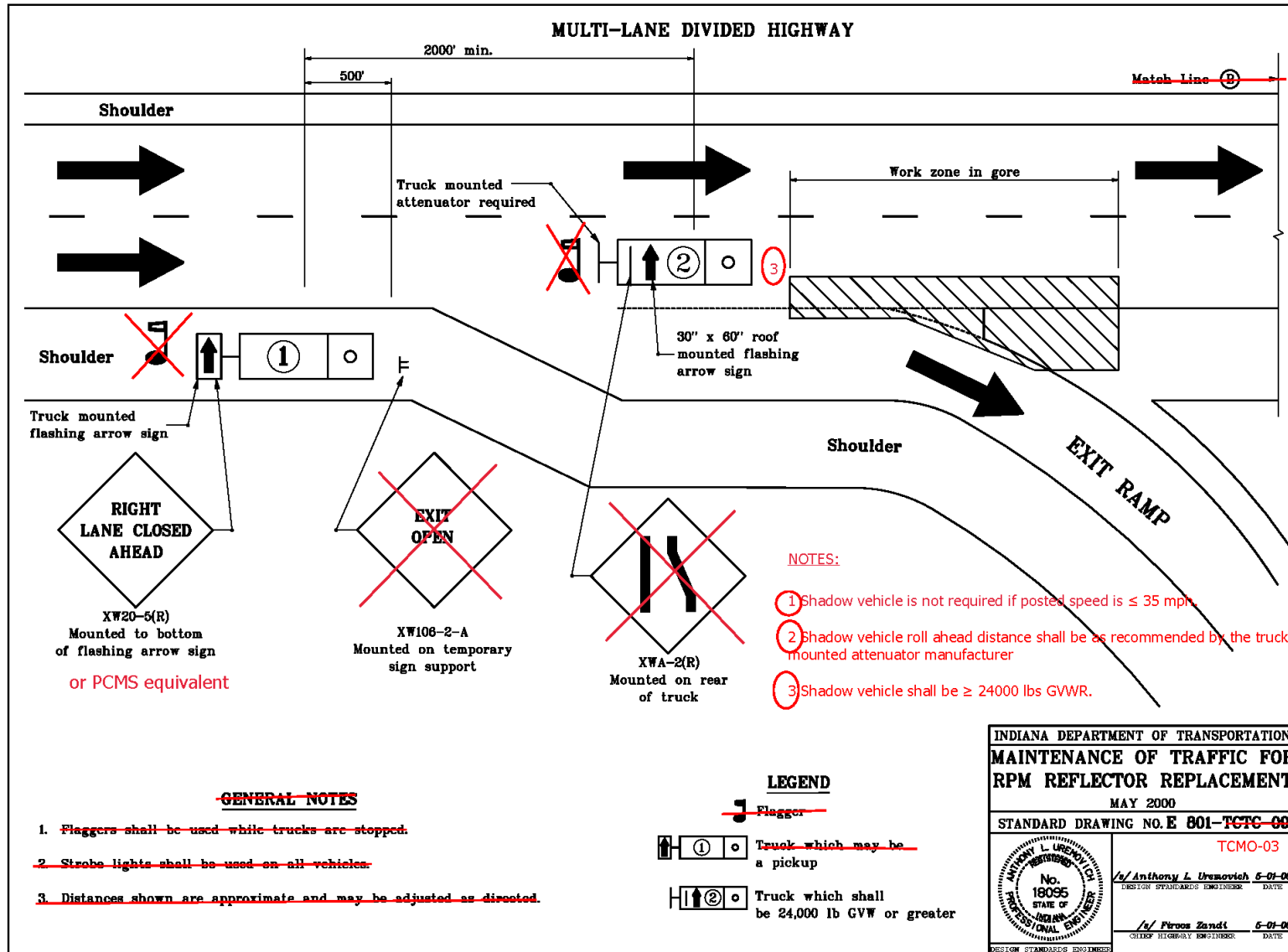

REVISION TO STANDARD DRAWINGS

E 801-TCTC-10 MAINTENANCE OF TRAFFIC FOR RPM REFLECTOR REPLACEMENT (WITH MARKUPS)

Move to new series on Traffic Control for Mobile Operations

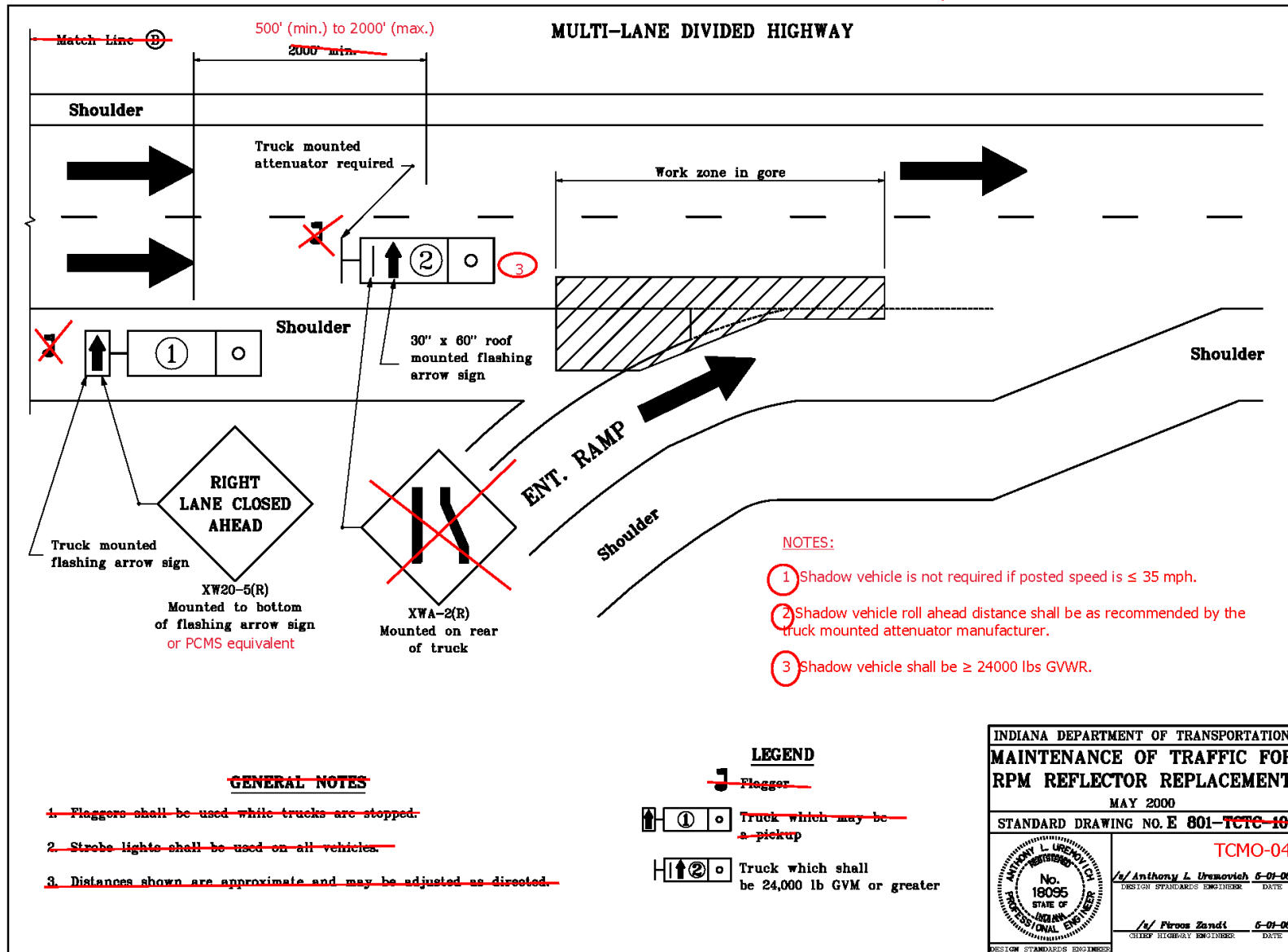

INDEX

SHEET NO.	SUBJECT
1	Flagger Operation for Two Lane Roads, Index and General Notes
2	Flagger Operation for Multiple Work Areas with Speed \geq 50 mph
3	Flagger Operation for Urban Two Lane Roads with Speed < 50 mph (Single Work Area)
4	Maintenance of Traffic for Mobile Operation with Flaggers for Two Lane Roads
5	Flagger Operation for Temporary Traffic Stoppage for Two Lane Roads

GENERAL NOTES:

1. Unless otherwise noted, the spacing of channelizing devices in tangent sections shall be 100 ft where the posted speed limit is 50 mph or greater, and the spacing shall be 50 ft where the posted speed limit is less than or equal to 45 mph.
2. For temporary lane closures during daylight hours, cones or tubular markers may be used in lieu of drums.
3. Temporary pavement markings shall not be required for temporary daylight lane closures
4. Channelizing devices as shown are schematic, the number of channelizing devices will vary based on field conditions.

INDIANA DEPARTMENT OF TRANSPORTATION

FLAGGER OPERATION FOR TWO LANE ROADS,
INDEX AND GENERAL NOTES

SEPTEMBER 2022

STANDARD DRAWING NO. E 801-TCFO-01

DESIGN STANDARDS ENGINEER DATE

CHIEF ENGINEER DATE

REVISION TO STANDARD DRAWINGS

E 801-TCFO-02 FLAGGER OPERATION FOR MULTIPLE WORK AREAS WITH SPEED \geq 50 MPH (PROPOSED DRAFT)

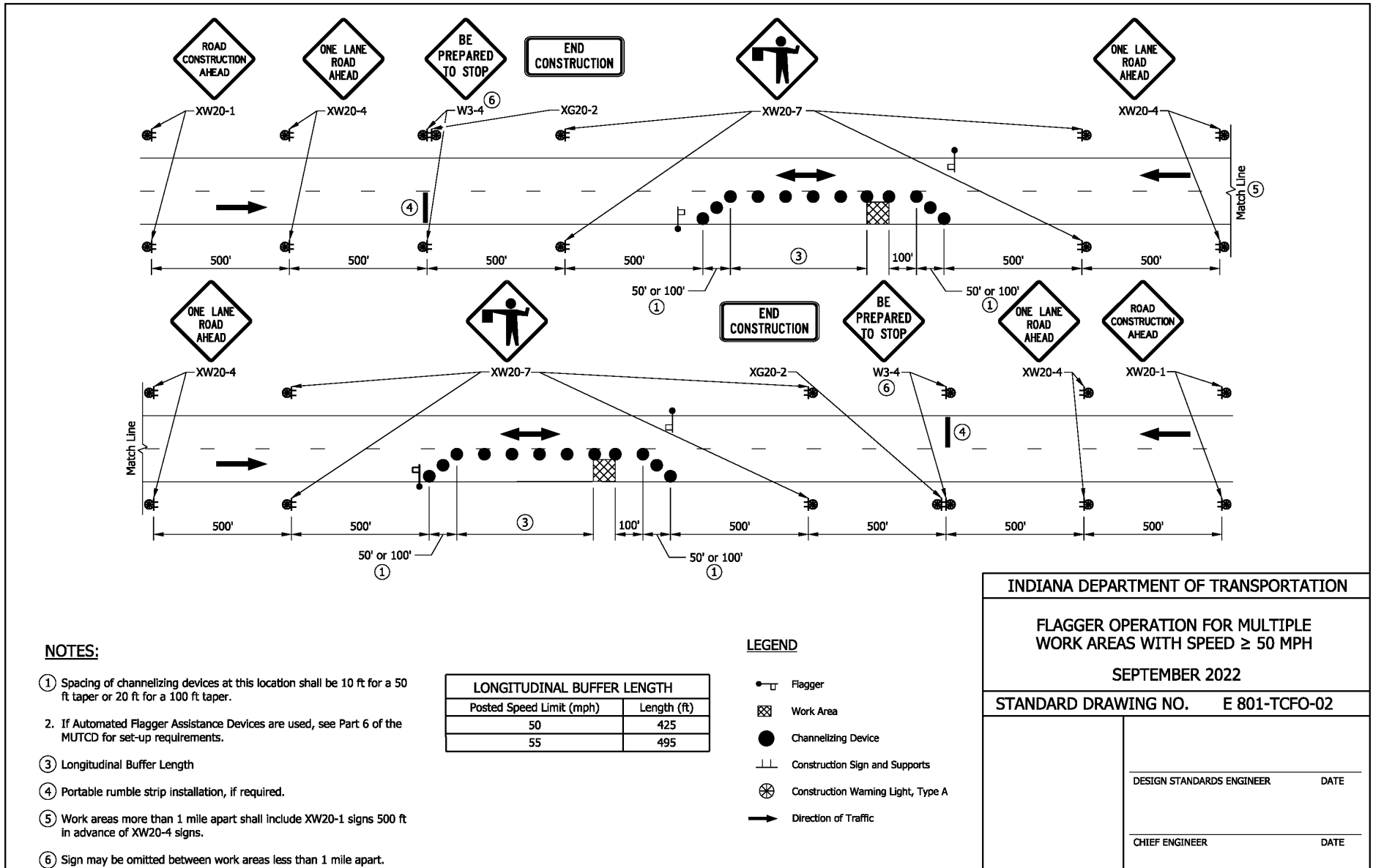

REVISION TO STANDARD DRAWINGS

E 801-TCFO-03 FLAGGER OPERATION FOR URBAN TWO LANE ROADS WITH SPEED < 50 MPH (SINGLE WORK AREA) (PROPOSED DRAFT)

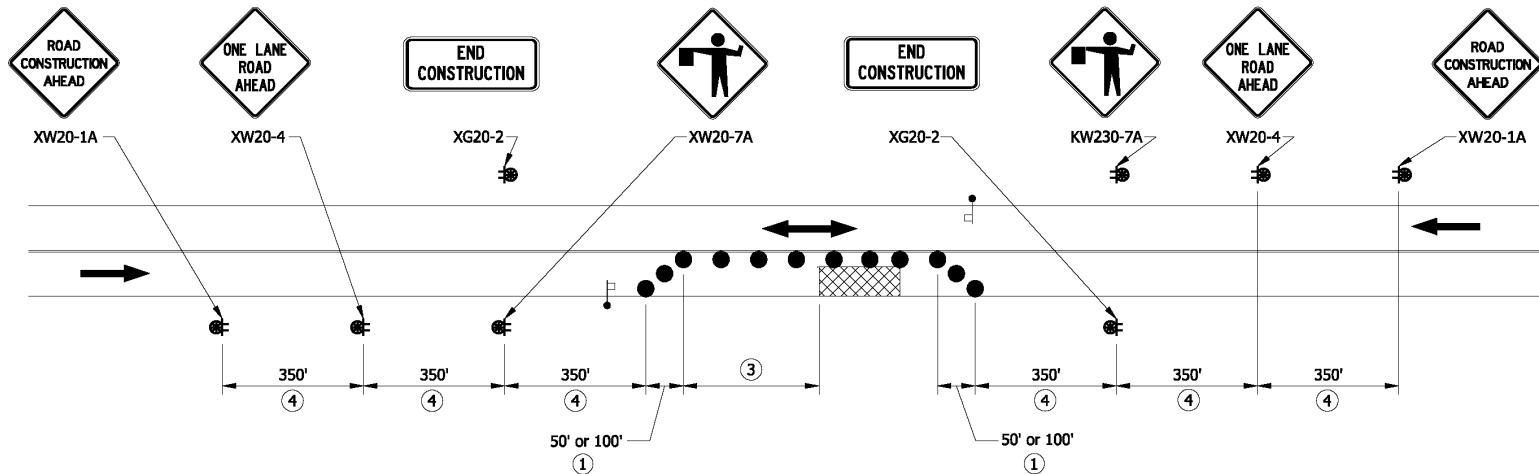

NOTES:

- ① Spacing of channelizing devices at this location shall be 10 ft for a 50 ft taper or 20 ft for a 100 ft taper.
- 2. If Automated Flagger Assistance Devices are used, see Part 6 of the MUTCD for set-up requirements.
- ③ Longitudinal Buffer Length
- ④ Sign spacing may be 100 ft for speed limits ≤ 35 mph.

LONGITUDINAL BUFFER LENGTH	
Posted Speed Limit (mph)	Length (ft)
≤30	200
35	250
40	305
45	360

LEGEND

- ◻ Flagger
- ▨ Work Area
- Channelizing Device
- ⊥ Construction Sign and Supports
- ⊗ Construction Warning Light, Type A
- ➔ Direction of Traffic

INDIANA DEPARTMENT OF TRANSPORTATION	
FLAGGER OPERATION FOR URBAN TWO LANE ROADS WITH SPEED < 50 MPH SINGLE WORK AREA	
SEPTEMBER 2022	
STANDARD DRAWING NO. E 801-TCFO-03	
DESIGN STANDARDS ENGINEER	DATE
CHIEF ENGINEER	DATE

REVISION TO STANDARD DRAWINGS

E 801-TCFO-04 MAINTENANCE OF TRAFFIC FOR MOBILE OPERATION WITH FLAGGERS FOR TWO LANE ROADS (PROPOSED DRAFT)

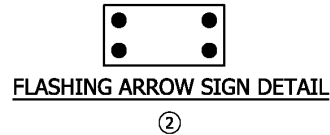
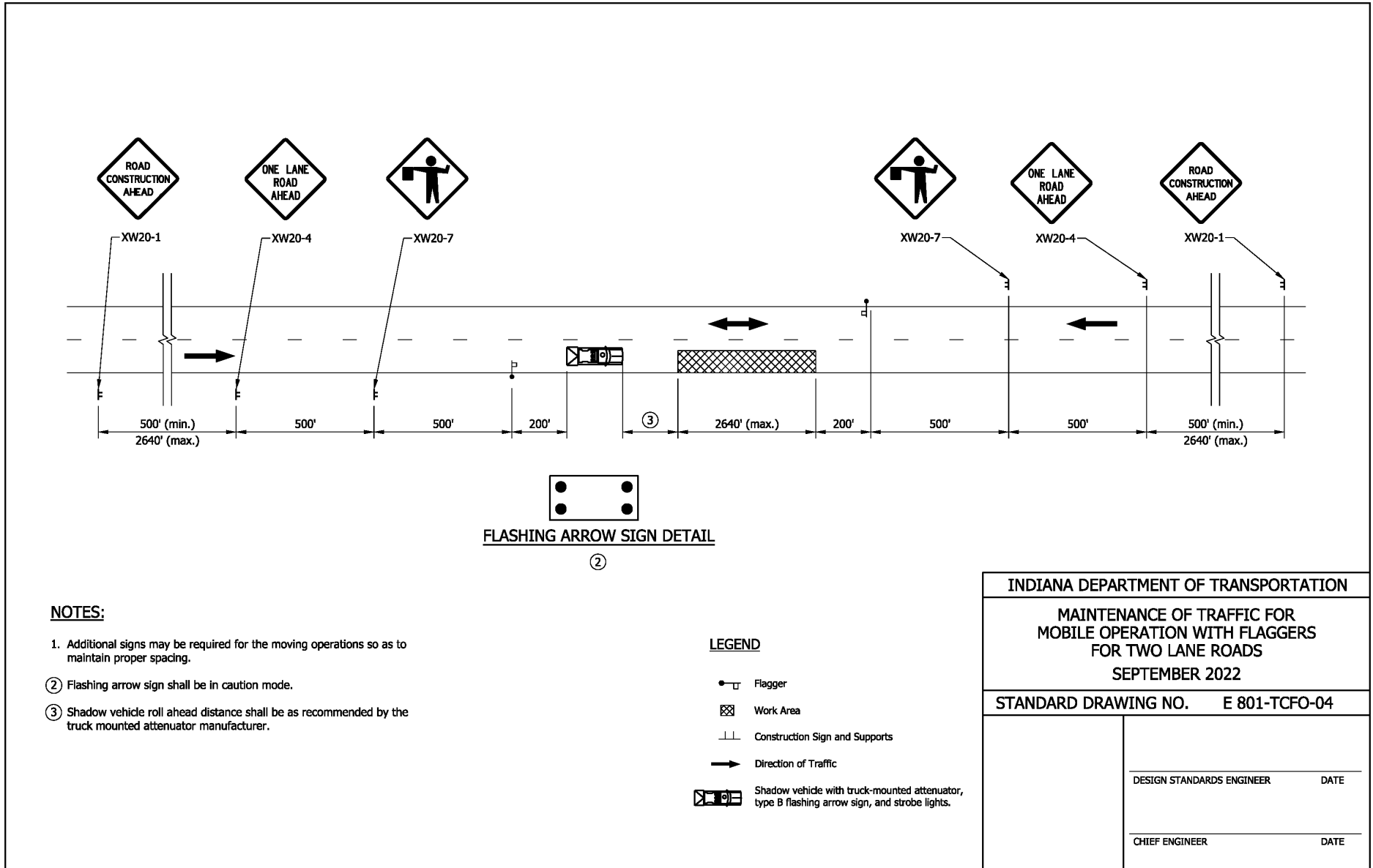

NOTES:

1. Additional signs may be required for the moving operations so as to maintain proper spacing.
- ② Flashing arrow sign shall be in caution mode.
- ③ Shadow vehicle roll ahead distance shall be as recommended by the truck mounted attenuator manufacturer.

LEGEND

- □ Flagger
- ▨ Work Area
- ⊥ ⊥ Construction Sign and Supports
- Direction of Traffic
- ☒ Shadow vehicle with truck-mounted attenuator, type B flashing arrow sign, and strobe lights.

INDIANA DEPARTMENT OF TRANSPORTATION	
MAINTENANCE OF TRAFFIC FOR MOBILE OPERATION WITH FLAGGERS FOR TWO LANE ROADS SEPTEMBER 2022	
STANDARD DRAWING NO. E 801-TCFO-04	
	DESIGN STANDARDS ENGINEER DATE
	CHIEF ENGINEER DATE

REVISION TO STANDARD DRAWINGS

E 801-TCFO-05 FLAGGER OPERATION FOR TEMPORARY TRAFFIC STOPPAGE FOR TWO LANE ROADS (PROPOSED DRAFT)

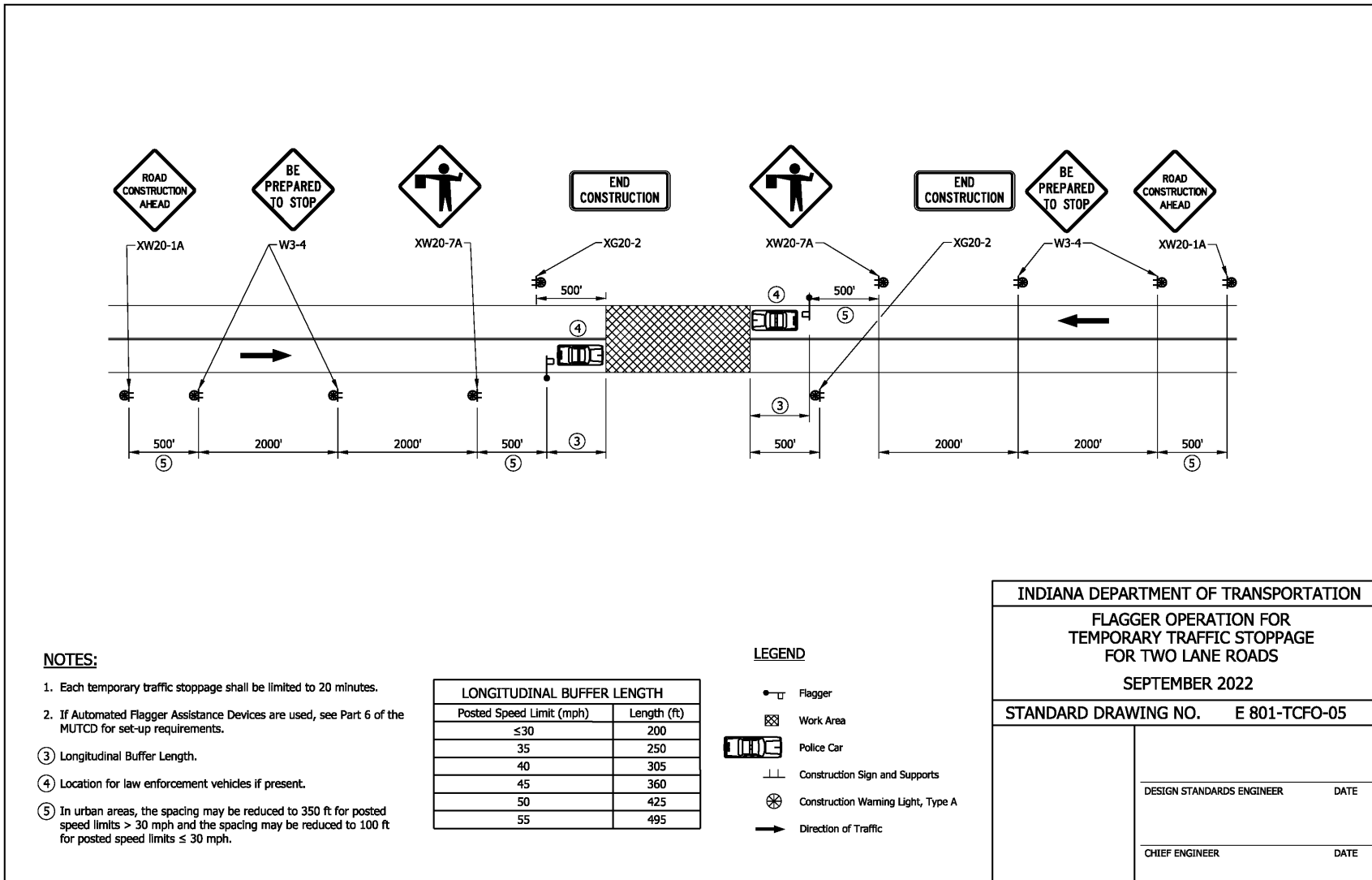

REVISION TO STANDARD DRAWINGS

E 801-TCMO-01 MOBILE OPERATION, INDEX AND GENERAL NOTE (PROPOSED DRAFT)

INDEX

SHEET NO.	SUBJECT
1	Mobile Operation, Index and General Note
2	Traffic Control for Mobile Operation on a Divided Highway
3	Maintenance of Traffic for RPM Reflector Replacement Near Exit Ramp
4	Maintenance of Traffic for RPM Reflector Replacement Near Entrance Ramp

GENERAL NOTE:

1. Strobe lights shall be used on all shadow vehicles.

INDIANA DEPARTMENT OF TRANSPORTATION	
MOBILE OPERATION, INDEX AND GENERAL NOTE	
SEPTEMBER 2022	
STANDARD DRAWING NO. E 801-TCMO-01	
	DESIGN STANDARDS ENGINEER DATE
	CHIEF ENGINEER DATE

REVISION TO STANDARD DRAWINGS

E 801-TCMO-02 TRAFFIC CONTROL FOR MOBILE OPERATION ON A DIVIDED HIGHWAY (PROPOSED DRAFT)

NOTES:

- ① Use XW20-5 sign or portable changeable message sign equivalent if speed limit is > 35 mph.
- ② If required by the Engineer, deploy additional shadow vehicle(s) with XW20-5 sign ¼ mi. in advance of any queue or as directed.
- ③ Shadow vehicle roll ahead distance shall be as recommended by the truck mounted attenuator manufacturer.

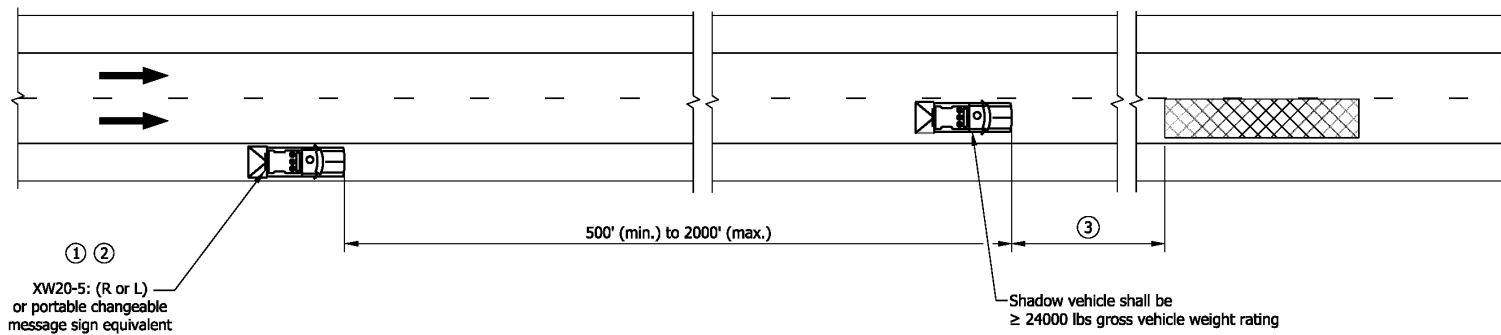



① ②
 XW20-5: (R or L)
 or portable changeable
 message sign equivalent



③
 Shadow vehicle shall be
 ≥ 24000 lbs gross vehicle weight rating

LEGEND

-  Shadow Vehicle with Truck Mounted Attenuator and Type B Flashing Arrow Sign
-  Mobile Work Area
-  Direction of Traffic

INDIANA DEPARTMENT OF TRANSPORTATION	
TRAFFIC CONTROL FOR MOBILE OPERATION ON A DIVIDED HIGHWAY	
SEPTEMBER 2022	
STANDARD DRAWING NO.	E 801-TCMO-02
DESIGN STANDARDS ENGINEER	DATE
CHIEF ENGINEER	DATE

REVISION TO STANDARD DRAWINGS

E 801-TCMO-03 MAINTENANCE OF TRAFFIC FOR RPM REFLECTOR REPLACEMENT NEAR EXIT RAMP (PROPOSED DRAFT)

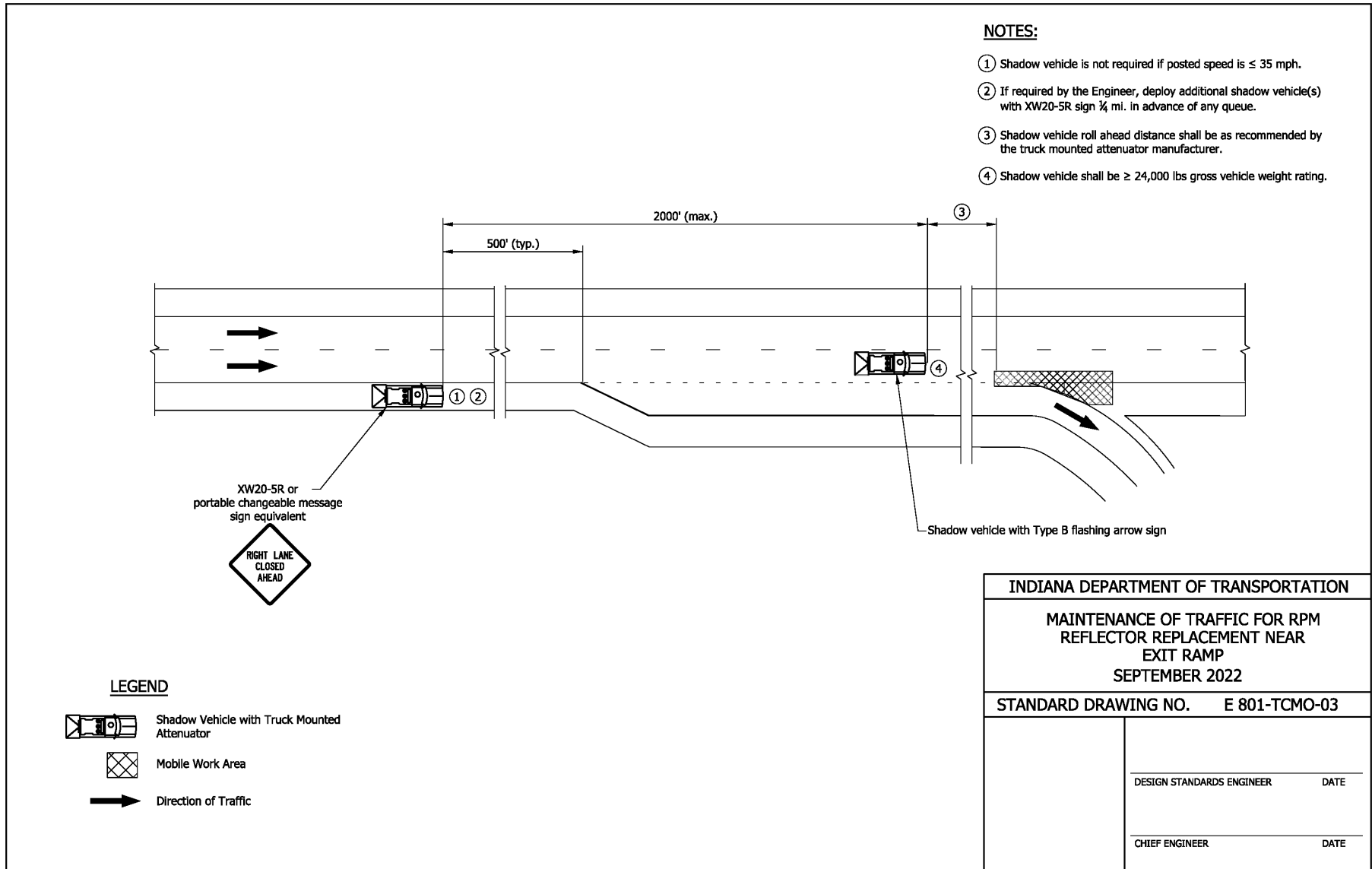

REVISION TO STANDARD DRAWINGS



E 801-TCMO-04 MAINTENANCE OF TRAFFIC FOR RPM REFLECTOR REPLACEMENT NEAR ENTRANCE RAMP (PROPOSED DRAFT)

NOTES:

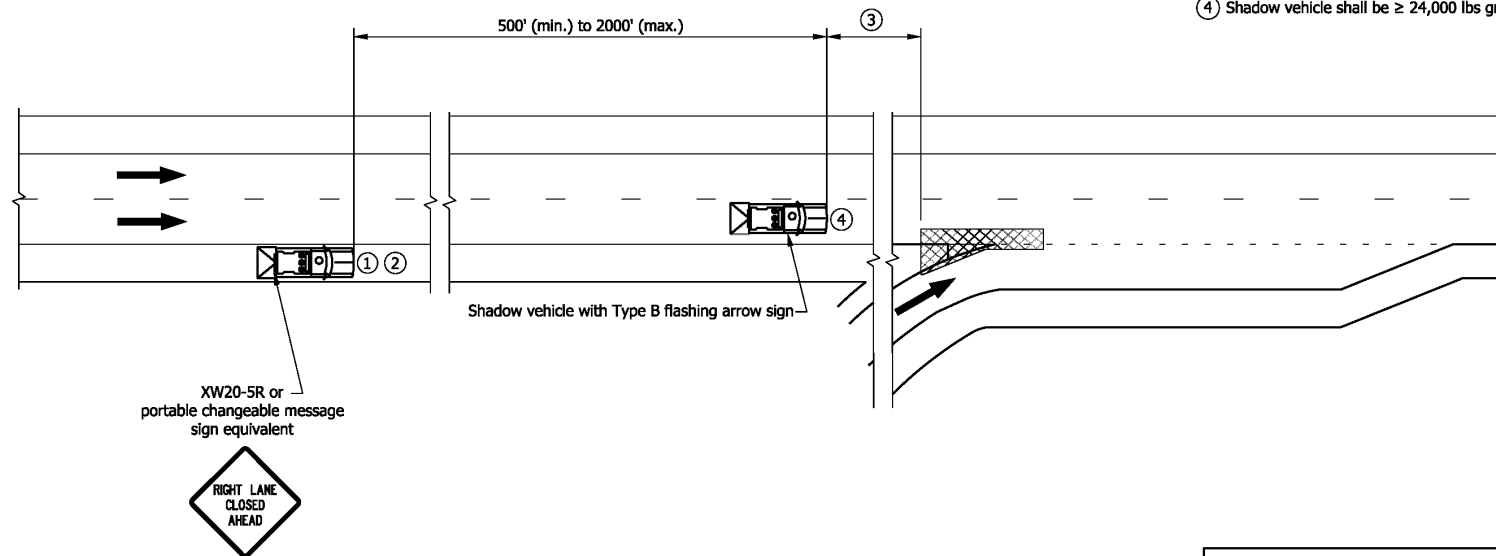
- ① Shadow vehicle is not required if posted speed is ≤ 35 mph.
- ② If required by the Engineer, deploy additional shadow vehicle(s) with XW20-5R sign $\frac{1}{4}$ mi. in advance of any queue or as directed.
- ③ Shadow vehicle roll ahead distance shall be as recommended by the truck mounted attenuator manufacturer.
- ④ Shadow vehicle shall be $\geq 24,000$ lbs gross vehicle weight rating.



LEGEND

-  Shadow Vehicle with Truck Mounted Attenuator
-  Mobile Work Area
-  Direction of Traffic

INDIANA DEPARTMENT OF TRANSPORTATION	
MAINTENANCE OF TRAFFIC FOR RPM REFLECTOR REPLACEMENT NEAR ENTRANCE RAMP SEPTEMBER 2022	
STANDARD DRAWING NO. E 801-TCMO-04	
	DESIGN STANDARDS ENGINEER _____ DATE _____
	CHIEF ENGINEER _____ DATE _____

COMMENTS AND ACTION

E 801-TCFO (series)

E 801-TCMO (series)

E 801-TCTC (series)

DISCUSSION:

This item was introduced and presented by Mr. Boruff who proposed to revise and update the standard drawing series on flagger operations (E 801-TCFO) and create a new series for mobile operations (E 801-TCMO), as described in the proposal sheet and as shown above. Mr. Boruff also proposed to delete unnecessary and duplicate details from the temporary closure series (E 801-TCTC). Further explanations were provided by Mr. Bruno.

Mr. Koch stated that 801-TCFO-02 & 03 reference 'speed', while other drawings reference 'speed limit' (801-TCMO-02) and 'posted speed' (801-TCMO-03 & 04). Ideally, we would use uniform terminology. Mr. Koch asked if the speed should be further defined, as a high speed roadway could have a temporary reduction. Design speed? Posted or temporary worksite speed? Or are we ok to use the shorter length of signage on a high speed roadway if a temp speed reduction is in place?

With regard to Note 4 on E 801-TCFO-05, Mr. Koch asked if the 'if present' LEO's should monitor the back of queue?

Mr. Boruff responded that he appreciates the suggestions on further defining terms, and being consistent too. The permanently posted speed limit should be used for these applications, even when we used reduced work zone speeds, driver compliance is inconsistent. If this description is a bit too long to fit into the title block, we can add a note on the drawings. Also, per the MUTCD (Chapter 6F, TA - 13) the law enforcement shown on TCFO-05 is an alternative to flaggers so they would be at the work area. LEO's for back of queue protection are a different measure.

Mr. Koch asked if further language could be included to convey that both are acceptable alternatives. Following further discussion, it was agreed that additional language is needed on the drawing for clarification.

Mr. Osborn asked if there is additional design guidance for the temporary rumble strips and LEOs. Mr. Boruff concurred, and further discussion will occur between Mr. Boruff and Mr. Osborn after the meeting.

Mr. Boruff revised his motion.

Mr. Pankow suggested these drawings be pulled so the agreed upon changes can be incorporated. Mr. Boruff agreed and withdrew this item.

COMMENTS AND ACTION

E 801-TCFO (series)

E 801-TCMO (series)

E 801-TCTC (series)

[continued]

<p>Motion: Mr. Boruff Second: Mr. Orton Ayes: Nays: FHWA Approval:</p>	<p>Action: ___ Passed as Submitted ___ Passed as Revised <u>X</u> Withdrawn</p>
<p>Standard Specifications Sections referenced and/or affected: NONE</p>	<p>___ 2024 Standard Specifications ___ Revise Pay Items List</p>
<p>Recurring Special Provision: <u>801-T-209</u> TEMPORARY PORTABLE RUMBLE STRIPS</p>	<p>___ Create RSP (No. __) Effective: RSP Sunset Date:</p>
<p>Standard Drawing affected: see proposal sheet</p>	<p>___ Revise RSP (No. __) Effective: RSP Sunset Date:</p>
<p>Design Manual Sections affected: NONE</p>	<p>___ Standard Drawing Effective:</p>
<p>GIFE Sections cross-references: NONE</p>	<p>___ Create RPD (No. __) Effective: ___ GIFE Update ___ Frequency Manual Update ___ SiteManager Update</p>

STANDARD SPECIFICATIONS, SPECIAL PROVISIONS AND STANDARD DRAWINGS
REVISION TO SPECIAL PROVISIONS

PROPOSAL TO STANDARDS COMMITTEE

PROBLEM(S) ENCOUNTERED: LEOs are used on contracts with increasing frequency and have been found to provide a positive impact on Work Zone Safety. Over the last few years, the LEO RSP has required revisions to update the provision to help meet the challenges for improved usage.

Additionally, with ISP's diminishing capability to staff construction contracts due to attrition and limits imposed on overtime, LEOs provided through the RSP help to meet the need for a law enforcement presence within identified work zones.

PROPOSED SOLUTION: Improve the RSP with modified language to clarify the use of authorized LEOs for Work Zone Safety and to help provide continued enhancement for contract queue protection and worker safety. Revision of the BFU is being proposed to provide significant contracts, in accordance with IDM Section 503-2.02, the use of the RSP.

APPLICABLE STANDARD SPECIFICATIONS: 801

APPLICABLE STANDARD DRAWINGS: N/A

APPLICABLE DESIGN MANUAL SECTION: 503-4.01

APPLICABLE SECTION OF GIFE: N/A

APPLICABLE RECURRING SPECIAL PROVISIONS: 801-R-672

PAY ITEMS AFFECTED: N/A

APPLICABLE SUB-COMMITTEE ENDORSEMENT: Ad hoc with Construction Management, Work Zone Safety, Design, EEO, and Industry

IF APPROVED AS RECURRING SPECIAL PROVISION OR PLAN DETAILS, PROPOSED BASIS FOR USE:

Revision to existing BFU: “Required for all contracts identified as significant in relation to work zone impacts in accordance with IDM Section 503-2.02 . For contracts identified as non-significant, as determined necessary by the **District Construction** [pay item: **801-12324**].”

IMPACT ANALYSIS (attach report):

Submitted By: Kurt Pelz

Title: Construction Management Tech Support

Organization: Construction Management

Phone Number: 317-691-4800

Date:

STANDARD SPECIFICATIONS, SPECIAL PROVISIONS AND STANDARD DRAWINGS
REVISION TO SPECIAL PROVISIONS

IMPACT ANALYSIS REPORT CHECKLIST

Explain the business case as to why this item should be presented to the Standards Committee for approval. Answer the following questions with Yes, No or N/A.

Does this item appear in any other specification sections? **No**

Will approval of this item affect the Approved Materials List? **No**

Will this proposal improve:

Construction costs? **No**

Construction time? **No**

Customer satisfaction? **Yes**

Congestion/travel time? **Yes**

Ride quality? **No**

Will this proposal reduce operational costs or maintenance effort? **No**

Will this item improve safety:

For motorists? **Yes**

For construction workers? **Yes**

Will this proposal improve quality for:

Construction procedures/processes? **Yes**

Asset preservation? **No**

Design process? **No**

Will this change provide the contractor more flexibility? **Yes**

Will this proposal provide clarification for the Contractor and field personnel? **Yes**

Can this item improve/reduce the number of potential change orders? **No**

Is this proposal needed for compliance with:

Federal or State regulations? **No**

AASHTO or other design code? **No**

Is this item editorial? **No**

Provide any further information as to why this proposal should be placed on the Standards Committee meeting Agenda:

REVISION TO SPECIAL PROVISIONS

801-R-672 LAW ENFORCEMENT OFFICER FOR WORK ZONE SAFETY

801-R-672 LAW ENFORCEMENT OFFICER FOR WORK ZONE SAFETY

(Revised 03-04-21)

Description

This work shall consist of providing a Law Enforcement Officer, LEO, to assist with the safe, efficient, orderly movement of traffic and to enhance worker safety during construction activities.

Materials

Materials shall be in accordance with 801.02 and as described herein.

Construction Requirements

Traffic Control and work zone safety shall be in accordance with 801 and the MUTCD. Utilization of the LEO may include providing a presence advanced warning for:

1. Maintenance of traffic set up, tear down, and substantial traffic shifts.
2. ~~When a~~ New lane closure arrangements are initiated for long term lane closures or shifts.
3. The first and last day of major changes in traffic control set up, and queue protection.
4. Other unique ~~project~~contract uses specified to enhance overall worker and motorist safety.

Use of a LEO by the Contractor ~~other than as specified above~~ will not be allowed at ~~project~~contract cost without the prior approval of by the Engineer. The LEO shall not be used where the MUTCD specifies that flaggers shall be used.

~~LEOs shall not be placed on contracts solely for EEO participation credit. There must be a Department recognized need for work zone queue protection or speed management, and prior approval by the Engineer for a LEO to be utilized and paid at the contract cost. When there is a Department recognized need for a LEO and the Contractor plans on utilizing the position for DBE, MBE, WBE, or IVBE participation credit, the LEO shall be submitted as a sub-contractor for the participation to count toward the EEO utilization goal.~~

LEO Personnel Requirements

The LEO shall be: ~~an off-duty, non-ISP Law Enforcement Officer in full police uniform. The LEO shall be a graduate of the Indiana Law Enforcement Academy Basic Course, or equivalent, and shall be a police officer or deputy actively employed by a police agency in Indiana. Equivalency of training will be at the discretion of the Department.~~

REVISION TO SPECIAL PROVISIONS

801-R-672 LAW ENFORCEMENT OFFICER FOR WORK ZONE SAFETY

- a) *an off-duty, non-ISP Indiana State Police Law Enforcement Officer in full police uniform, and*
- b) *a graduate of an Indiana approved Law Enforcement Academy, and*
- c) *a police officer or deputy actively employed by a police agency in Indiana.*

In accordance with IC 8-23-2-15(b), the duties of a police officer hired under this special provision shall:

- 1. Be limited to those duties that the police officer normally performs while on active duty; and
- 2. Not include the duties of a
 - a. Flagman; or
 - b. Security Officer.

Equipment

The LEO shall use a marked police vehicle with emergency flashing lights and complete markings of the appropriate law enforcement agency. At a minimum, the marked police vehicle shall be equipped with an 800 MHz radio/portable radio that contains the local and statewide mutual aid channels within the area the LEO is working.

When outside of the marked police vehicle, the LEO shall wear the correct ANSI certified high-visibility safety apparel provided by their agency.

Operation

The Contractor shall be responsible for securing the services of the LEO with the appropriate agency and communicating the intentions of the plans with respect to the duties of the LEO *as approved by the Engineer*. The Contractor and the LEO shall follow the standards for placement of the LEO in work zones set forth by the NCHRP Report 746.

The Contractor shall establish direct communication with the LEO prior to the start of their shift. The method of communication shall be at the discretion of the Contractor and may include the exchange of mobile telephone numbers or dedicated communication devices, such as mobile phones and walkie-talkies. The Contractor may provide the LEO with dedicated communication devices. Contractor provided dedicated communication devices shall be returned to the Contractor at the end of the LEO's shift.

Training

Training for the LEO, the Contractor, and the Engineer will be conducted in two parts. Both ~~trainings~~ parts shall ~~occur~~ be completed prior to ~~individuals beginning involvement in~~ traffic maintenance operations on the contract. The first part of the training will be ~~an individual web-based training~~ and provide concepts and reasoning for the use of LEOs on Department contracts. The second part of the training will ~~be a~~

REVISION TO SPECIAL PROVISIONS

801-R-672 LAW ENFORCEMENT OFFICER FOR WORK ZONE SAFETY

~~discussion-based training provide supplementary guidance for LEOs working within Department work zones. At the end of the second training, all parties shall sign the signature page to attest they have completed both portions of the law enforcement officer training.~~

Part 1

~~Prior to involvement in maintenance of traffic operations, the LEO, at least one representative of the Contractor who will be onsite when the LEO is present, and the Engineer, shall complete the Department's web based "Law Enforcement Officers in INDOT Work Zones Training". The training consists of three modules and is available on the Work Zone Safety website located at <https://www.in.gov/indot/3980.htm>. <https://www.in.gov/indot/safety/work-zone-safety/law-enforcement-officers-for-work-zone-safety/>.~~

~~The names of any additional individuals proposing to take this training shall be submitted to the Engineer prior to taking the training.~~

Part 2

~~The LEO, the Contractor, and the Engineer are also required to review and agree to adhere to the requirements contained in Department specific training entitled "Instructions and Procedures For Non-ISP Law Enforcement Officers When Working in INDOT Work Zones" prior to beginning maintenance of traffic operations. The training document is accessible available on the Work Zone Safety Website located at <https://www.in.gov/indot/3980.htm> <https://www.in.gov/indot/safety/work-zone-safety/law-enforcement-officers-for-work-zone-safety/>.~~

~~All individuals completing Parts 1 and 2 training shall sign the signature page located at the end of the Part 2 training document. By signing, individuals shall be confirming they have completed Parts 1 and 2 of the law enforcement training requirements.~~

~~The Part 2 training instruction document, any training notes, and the signature document will be retained within the contract files.~~

Engineer Responsibilities

~~The activities of the LEO are subject to the authority and direction of the Engineer, in accordance with 105 and 108, and are limited to the activities associated with the contract work zone. The Contractor's choice of duties and placement of the LEO on any given work shift are subject to approval by the Engineer. The Engineer will have no authority over the LEO when the LEO is acting in ~~ana~~ law enforcement agency enforcement capacity. The Engineer may direct the LEO to perform enforcement and other unspecified activities to encourage motorists to respect the work zone. Other ~~unspecified uses~~ ~~unspecified~~ activities of the LEO will not be allowed without the prior approval of the Engineer.~~

Contractor Responsibilities

~~The Contractor shall be responsible for the LEO's duties and placement. and The Contractor shall inform the Engineer of ~~any~~ all planned LEO activities, any issues that may arise, and when the LEO leaves the construction site for any reason. Duties and placement of the LEO are~~

REVISION TO SPECIAL PROVISIONS

801-R-672 LAW ENFORCEMENT OFFICER FOR WORK ZONE SAFETY

subject to approval by the Engineer. The Contractor shall ~~ensure~~ verify that the LEO remains at the ~~project construction~~ site for the entire duration of their shift and reports back at the end of the shift unless directed otherwise by the Engineer.

LEO Responsibilities

The LEO shall report to the Contractor prior to the start of the shift in order to receive instructions regarding specific work assignments. The LEO shall ~~stay remain~~ at the ~~project construction~~ site for the entire duration of their shift ~~and report to the Contractor at the end of the shift~~. If the LEO has completed the duties described above and still has time remaining on their shift, the LEO may be asked to patrol through the work zone, with flashing lights off, or be placed at a location to deter motorists from speeding or following too closely. ~~When it is necessary to leave the project site~~ At the end of the shift, the LEO shall ~~first~~ notify the Contractor *before leaving the construction site*. ~~The Contractor shall then notify the appropriate Department personnel.~~

All LEOs shall follow the procedures for infraction and ordinance violation enforcement established by IC 9-21-5-11 while working within the work zone. This shall include issuing citations for infractions or detaining individuals in violation of traffic laws when and where appropriate.

The LEOs shall not forgo their traffic control responsibilities to apprehend motorists for routine traffic violations, except that enforcement action is encouraged to enhance motorist compliance and increase driver awareness. If a motorist's actions are considered reckless or endangering to the workers or to the motoring public, then pursuit of the motorist is appropriate. LEOs shall also ~~provide a response~~ respond to any incident or situation ~~that involves~~ involving public safety, including but not limited to crashes, near or within the ~~project contract~~ limits to ensure the safety of the parties involved, and the motoring public. *When it is necessary for the LEO to leave the construction site under these circumstances, the LEO shall notify the Contractor as soon as reasonably possible.*

Method of Measurement

Law enforcement officer for work zone safety will be measured by the number of hours during ~~the phase or phases of~~ traffic control ~~phases that require the LEO's presence~~ requiring a LEO. Each portion of an hour will be measured as a whole hour.

If a LEO is directed, by their agency, to respond to a situation ~~that is~~ not related to the contract, the time *away from the contract* involved in responding to that situation will not be measured for payment.

Law enforcement officer training will not be measured for payment.

Basis of Payment

Law enforcement officers will be paid for at the contract unit price of \$60 per hour.

REVISION TO SPECIAL PROVISIONS

801-R-672 LAW ENFORCEMENT OFFICER FOR WORK ZONE SAFETY

Training shall be included in the cost of other items.

Payment will be made under:

Pay Item

Pay Unit Symbol

Law Enforcement Officer.....HR

APPROVED MINUTES

BACKUP 1

2013 Indiana Design Manual, Ch. 503 (excerpt, proposed draft)

503-4.0 TRANSPORTATION OPERATIONS PLAN

The Transportation Operations Plan (TOP) is the set of strategies that will be used to minimize adverse impacts in the work zone and must be incorporated into the TMP of any project that is determined to have significant work zone impacts. TOPs may also be provided as needed for projects that are not defined as having significant work zone impacts.

The TOP includes strategies for the operations and management of the work zone and all facilities affected by the work zone, which can include transit, rail, air, and pedestrians. The proposed mitigation measures should also be included in the TOP. These strategies may include traffic incident management plans, planned special events, Intelligent Traffic System (ITS) components, maintenance or enhancement of other modes of transportation, emergency service provider access and communication, work zone law enforcement, and other related strategies. The TOP must include the proposed methodology for monitoring and measuring mobility during the active work zone phase.

503-4.01 TOP Development

For an INDOT project, the TOP is developed by the District Traffic Office, in coordination with the Traffic Management Division and the LPA(s). For any given project, other members of the TMP Team may also be involved in the development of the TOP. Depending on the traffic mitigation measures initially identified, other offices may be involved in the development of the TOP to ensure that it is successfully planned and implemented.

The following strategies should be considered in developing an effective TOP:

1. **Tow Trucks for Incident Management.** The use of on-site tow trucks should be considered for a freeway work zone with limited or unavailable shoulder width. These trucks should also be considered where a crash or vehicle breakdown can seriously impact traffic flow and cause excessive backups and delays. A separate pay item for Tow Truck should be included in the cost estimate.
2. **Interconnection of Traffic Signals.** The addition of interconnected traffic signals should be considered where the benefit of moving traffic more efficiently

BACKUP 1

2013 Indiana Design Manual, Ch. 503 (excerpt, proposed draft)

through a work zone will be significantly enhanced.

3. Lane Rental by Contractor. In this application, a contractor formulates its bid around the number of hours that it expects to keep a number of lane-miles closed, and then can earn or lose money if the actual number of hours is higher or lower than that bid. This concept has not had widespread use to date. Police Patrol for Speed Control. A police patrol can be required to ensure that vehicular speeds are at or below the posted speed limit, or for other safety reasons. Because this requires a special funding mechanism and special provisions, the designer should coordinate this with the Traffic Management Division. If access from one direction of travel to the other (across the roadway) is restricted, median openings or turnarounds should be considered to facilitate enforcement. No U-turn signs should be provided for interstate median openings.
4. (Local) Law Enforcement Officers for Work Zone Safety. Local law enforcement officers (LEOs) *authorized by the Department and* hired by the contractor may be specified for a contract to enhance work zone safety. Officers can be used for a number of purposes including
 - a. queue protection;
 - b. serving as a presence behind any operation being performed adjacent to live traffic, even if the work is taking place only on the shoulder or utilizing a buffer zone;
 - c. issuing citations for violations within the work zone;
 - d. responding to an emergency within the work zone;
 - e. responding to an incident or emergency near the work zone that might affect traffic flow or safety.

Officers should not be used for the following:

- a. serving as a presence while officer's vehicle is stationed in work zone behind a temporary barrier wall;
- b. serving as presence while their vehicle is stationed on a road or ramp that has already been closed with barricades;
- c. providing flagging assistance.

Include LEO use for contracts identified as significant in relation to work zone impacts in accordance with Section 503-2.02. For contracts identified as non-significant, District Construction will make a project-specific determination to

BACKUP 1

2013 Indiana Design Manual, Ch. 503 (excerpt, proposed draft)

include LEOs. The TMP team or designer may consider whether LEO presence will be beneficial and make a recommendation accordingly.

When LEOs will be used, RSPs 801-R-672, Law Enforcement Officer for Work Zone Safety, and ~~801-R-672A, Guidelines for Law Enforcement Officers When Working in INDOT Work Zones~~, should be included in the contract documents with the appropriate pay item. LEOs are paid for on an hourly basis as noted in the RSP.

5. Ramp Closure, Short or Intermediate Term. If a shorter intermediate-term ramp closure is necessary, additional signage will be necessary to forewarn motorists. Signs should be posted on the affected ramp two weeks in advance to advise motorists of the closure date or portion of the day during which the ramp will be closed.

APPROVED MINUTES

COMMENTS AND ACTION

801-R-672 LAW ENFORCEMENT OFFICER FOR WORK ZONE SAFETY

DISCUSSION:

This item was introduced and presented by Mr. Pelz, who stated that LEOs are used on contracts with increasing frequency and have been found to provide a positive impact on Work Zone Safety. Over the last few years, the LEO RSP has required revisions to update the provision to help meet the challenges for improved usage.

Mr. Pelz also mentioned that with ISP's diminishing capability to staff construction contracts due to attrition and limits imposed on overtime, LEOs provided through the RSP help to meet the need for a law enforcement presence within identified work zones.

Mr. Pelz proposed to improve the RSP with modified language to clarify the use of authorized LEOs for Work Zone Safety and to help provide continued enhancement for contract queue protection and worker safety. Revision of the BFU is being proposed to provide significant contracts, in accordance with IDM Section 503-2.02, the use of the RSP.

Prior to the meeting, Mr. Koch asked if individual qualifying governmental LEO's okay to be submitted as subs, which could be a lot of subs, or is this only for firms that have LEO's of staff? The LEO costs can easily overrun considerably as daily reporting logs run behind. Mr. Koch said that he has been informing Contractors during the preconstruction meeting that the item cannot be overrun without Department approval in order to force timely reporting and the use of an appropriate number of LEO's. Not sure if this has been a problem elsewhere and would prefer to not list who needs to approve, for everyone else, if an overrun occurs.

Mr. Pelz responded that we have had issues with southern Districts having Primes trying to use unauthorized LEOs on contracts to satisfy EEO requirements. The added statement is intended to help provide the concept that adding an unauthorized LEO to a contract just to satisfy contract EEO requirements is not to occur. If there is a need for a LEO, and the LEO used will satisfy the EEO requirements, then that LEO will need to be submitted as a sub-contractor for credit to be used. If the LEO does not qualify as a DBE, MBE, WBE, or IVBE, they cannot be used to help satisfy the contract EEO requirements. This statement has been reviewed by EOD Director Elizabeth Kiefner.

As for the second question, Mr. Pelz stated that he has personally not heard of this issue occurring elsewhere, but it definitely could be. LEOs are to be paid on contracts at the authority of the Department. Additional statements to this provision reinforce that concept. If a Contractor hires a LEO on their own to be used on a contract without the authority of the Department, the PE/PS is not obligated to pay for the LEO unless they authorize their use.

Mr. Koch asked if a clarifying statement should be included to make the credit process solely for non-governmental entities? From my limited understanding of DBE, MBE, WBE, or IVBE; each would need to be an approved EEO entity prior to being approved as a subcontractor. Although against our established DBE practice, a contractor may attempt to summarize a number of governmental agency's participation. Is it problematic to require a subcontract for a DBE but not a majority company?

Mr. Koch further inquired if the southern Indiana LEO's company is unauthorized, can the situation be resolved at the field level with proper PE/PS understanding? Or have companies elected to use LEO's at

COMMENTS AND ACTION

801-R-672 LAW ENFORCEMENT OFFICER FOR WORK ZONE SAFETY

their own expense for safety & EEO? If so, the RSP may not be enacted within the CIB; meaning that the controlling language would not present to prevent the problem.

Mr. Pelz said that governmental agencies would not qualify as a DBE, MBE, WBE, or IVBE. This would make the additional statement irrelevant. Per the RSP, a PE/PS should be aware of the particular LEOs that are present on the job at any one time. Further, a sub-contract would only be required for a LEO when 1) the LEO position is authorized by the Department for the contract, 2) the LEO meets the EEO requirements set forth by the Department, and 3) the Contractor wishes to use the LEO to capture a portion of the contract EEO goal. The LEO hired for this position shall be an approved DBE, MBE, WBE, or IVBE.

Mr. Pelz also added that the LEO shall be an approved sub-contractor only when used to meet an EEO contract goal. A LEO not used to meet EEO requirements is considered to provide a "professional service" and is not required to have a sub-contract. This was discussed and resolved with EOD in 2019.

Mr. Pelz then mentioned that the PE/PS could resolve the issue of authorized use of a LEO for a contract if they speak with their AE and get concurrence. This might be used to authorize a LEO for extra hours as you have stated earlier. The choice to use a LEO for EEO requirements shall be made prior to letting by the Contractor. This is not an issue that could be resolved after letting by the PE/S.

Mr. Koch asked how is this different from our normal 103 process? "Only special classes approved by EEO receive credit. And PE/PS should be able to tell a contractor "no" to control hours, placement, and whether they are a graduate of an Academy, off duty, and actively employed. I agree that other governmental agencies cannot be a subcontractor although the proposed language could be read that an individual LEO may become an approved subcontractor which I do not believe is acceptable either. Perhaps bidders will know & understand this." Ms. Keefer offered further concerns related to Mr. Koch's comments. Mr. Pelz agreed to remove that new paragraph at this time.

Mr. Pelz shared that our EOD has stated that "LEO Officers are not subject to Davis-Bacon wages as they are not to be doing any physical labor on the site of work and are only performing functions in their uniforms and fully marked police vehicles. They are also not required to be submitted as subcontractors, unless the firm providing these services are a DBE firm. If the firm is a DBE then they would need to be submitted in order to capture the DBE participation."

Minor revisions are as shown above.

COMMENTS AND ACTION

801-R-672 LAW ENFORCEMENT OFFICER FOR WORK ZONE SAFETY

[continued]

<p>Motion: Mr. Pelz Second: Mr. Novak Ayes: 10 Nays: 0 FHWA Approval: YES</p>	<p>Action:</p> <p><input type="checkbox"/> Passed as Submitted <input checked="" type="checkbox"/> Passed as Revised <input type="checkbox"/> Withdrawn</p>
<p>Standard Specifications Sections referenced and/or affected:</p> <p>801 pg 863 -889.</p>	<p><input type="checkbox"/> 2024 Standard Specifications</p> <p><input type="checkbox"/> Revise Pay Items List</p>
<p>Recurring Special Provision references in:</p> <p>801-R-672 LAW ENFORCEMENT OFFICER FOR WORK ZONE SAFETY</p>	<p><input type="checkbox"/> Create RSP (No. __) Effective: RSP Sunset Date:</p>
<p>Standard Drawing affected:</p> <p>NONE</p>	<p><input checked="" type="checkbox"/> Revise RSP (No. <u>801-R-672</u>) Effective: <u>March 1, 2022</u> RSP Sunset Date:</p>
<p>Design Manual Sections affected:</p> <p>503-4.01</p>	<p><input type="checkbox"/> Standard Drawing Effective:</p>
<p>GIFE Sections cross-references:</p> <p>NONE</p>	<p><input type="checkbox"/> Create RPD (No. __) Effective:</p> <p><input type="checkbox"/> GIFE Update <input type="checkbox"/> Frequency Manual Update <input type="checkbox"/> SiteManager Update</p>

STANDARD SPECIFICATIONS, SPECIAL PROVISIONS AND STANDARD DRAWINGS
REVISION TO SPECIAL PROVISIONS

PROPOSAL TO STANDARDS COMMITTEE

PROBLEM(S) ENCOUNTERED: Changes were made to the 214 geotextiles section and RSP 214-R-733 was created and becomes effective with December lettings. There is confusion because there are references to geotextile for subgrade and geotextile for embankment in the standard drawings but no pay items for these items.

PROPOSED SOLUTION: Both geotextile for subgrade and geotextile for embankment use the same material as geotextile for pavement. Thus to clear things up, add a sentence to the Basis of Payment section of RSP 214-R-733 as shown in the item.

APPLICABLE STANDARD SPECIFICATIONS: None

APPLICABLE STANDARD DRAWINGS: NA

APPLICABLE DESIGN MANUAL SECTION: NA

APPLICABLE SECTION OF GIFE: NA

APPLICABLE RECURRING SPECIAL PROVISIONS: RSP 214-R-733

PAY ITEMS AFFECTED: NA

APPLICABLE SUB-COMMITTEE ENDORSEMENT: Ad hoc: Jim Reilman & Nayyar Siddiki

IF APPROVED AS RECURRING SPECIAL PROVISION OR PLAN DETAILS, PROPOSED BASIS FOR USE:
The existing BFU for 214-R-733 can continue to be used.

IMPACT ANALYSIS (attach report):

Submitted By: Jim Reilman

Title: State Materials Engineer

Organization: INDOT Materials and Tests

Phone Number: 317-522-9692

Date: 8/27/21

STANDARD SPECIFICATIONS, SPECIAL PROVISIONS AND STANDARD DRAWINGS
REVISION TO SPECIAL PROVISIONS

IMPACT ANALYSIS REPORT CHECKLIST

Explain the business case as to why this item should be presented to the Standards Committee for approval. Answer the following questions with Yes, No or N/A.

Does this item appear in any other specification sections? N

Will approval of this item affect the Approved Materials List? N

Will this proposal improve:

Construction costs? N

Construction time? N

Customer satisfaction? N

Congestion/travel time? N

Ride quality? N

Will this proposal reduce operational costs or maintenance effort? N

Will this item improve safety:

For motorists? N

For construction workers? N

Will this proposal improve quality for:

Construction procedures/processes? N

Asset preservation? N

Design process? N

Will this change provide the contractor more flexibility? N

Will this proposal provide clarification for the Contractor and field personnel? Y

Can this item improve/reduce the number of potential change orders? Y

Is this proposal needed for compliance with:

Federal or State regulations? N

AASHTO or other design code? N

Is this item editorial? N

Provide any further information as to why this proposal should be placed on the Standards Committee meeting Agenda:

REVISION TO SPECIAL PROVISIONS

214-R-733 GEOSYNTHETICS

214-R-733 GEOSYNTHETICS

(Adopted 05-20-21)

The Standard Specifications are revised as follows:

SECTION 214, BEGIN LINE 1, DELETE AND INSERT AS FOLLOWS:

SECTION 214 – GEOSYNTHETICS

214.01 Description

This work shall consist of furnishing and installing geosynthetics as shown on the plans or as directed by the Engineer and in accordance with 105.03.

MATERIALS

214.02 Materials

Materials shall be in accordance with the following:

Coarse Aggregate	904.03 *
Geocell Confinement System	918.04
Geogrid	918.05
Geotextile for Pavement and Subgrade	918.02

Notes: Coarse Aggregate*Only No. 2, 5, 43, 53, 73, shall be used only. ACBF Slag shall not be allowed used.

CONSTRUCTION REQUIREMENTS

214.03 Foundation Preparation

The embankment foundation shall be cleared and grubbed in accordance with 201 and excavated using lightweight equipment to minimize disturbance of the embankment foundation surface soils. Construction activities using equipment which cause pumping and rutting of the embankment foundation soils shall be prevented where possible and shall otherwise be minimized. Fine grading may be waived where impractical. When very soft soil is encountered, the embankment foundation shall be cleared of all trash and rubbish materials without disturbing the vegetation cover or root mat. The embankment foundation shall be subject to approval prior to placement of geosynthetics. Proofrolling of the embankment foundation will not be required in accordance with 203.09 when geosynthetics are used in construction of embankment foundation treatment.

(a) Geotextile as a Drainage Blanket

Geotextile shall be stored in such a manner as to prevent exposure to direct sunlight and damage by other construction activities. Geotextile shall be placed taut and transversely after backfilling all wheel tracks. Geotextile shall be overlapped by 3 ft and sewn in accordance with the manufacturer’s guidelines.

REVISION TO SPECIAL PROVISIONS

214-R-733 GEOSYNTHETICS

Coarse aggregate No. 2 or No. 5 shall be placed as directed and encapsulated with geotextile. Coarse aggregate shall be placed by spreading dumped material over previously placed material with light equipment in such a manner as to prevent damage to the geotextile. Dumping of coarse aggregate will be allowed on *the* initial working platform. The overlap shall be staggered throughout the roadway profile. Coarse aggregate shall be placed to the full required thickness and compacted before any loaded trucks are allowed on the blanket. The drainage blanket shall have positive drainage.

No vehicles or construction equipment ~~shall~~ *will* be allowed on the geotextile prior to placement of the coarse aggregate. Damaged geotextile shall be repaired or replaced as directed. Damaged geotextile may be patched by placing a piece of the same geotextile over the damaged area. The overlap shall be at least 3 ft wide. The remaining lifts of the embankment shall be in accordance with 203.23.

(b) Geotextile Placement for Pavement, Subgrade, or Embankment

The subgrade or embankment shall be proofrolled in accordance with 203.26 and any defect or rut shall be repaired as directed prior to the geotextile placement. Geotextile shall be placed taut, without wrinkles and stretched in tension. Coarse aggregate shall be placed with a minimum disturbance to grade. Any damage to geotextile shall be repaired in accordance with 214.03(a). The remaining grade shall be constructed in accordance with 207. *Geotextile for pavement, subgrade, or embankment shall be in accordance with 918.02(c).*

When geotextile for moisture management is specified, the grade shall be prepared in such a way as to provide positive drainage. The surface shall be prepared in accordance with 201.03 and compacted in accordance with 203.23. All rocks shall be broken and compacted in accordance with 203.24. Geotextiles shall be placed taut, without wrinkles, in accordance with the manufacturer's guidelines, as shown on the plans, or as specified. Damaged geotextile shall be replaced. Geotextile for moisture management shall be in accordance with 918.02(d).

Geotextile shall be covered within three calendar days of placement.

(c) Geogrid Placement in Embankment and Subgrade

The geogrid shall be installed in accordance with the Engineer's designs or the manufacturer's recommendations. The geogrid shall be kept taut during placement of the initial lift of backfill. Installation shall require the use of stakes, staples, sandbags, pile of granular fill, or other approved means to hold the geogrid in place during fill placement operations. ~~Type IA geogrid shall be used for embankment foundation treatment. Type IB geogrid shall be used for subgrade treatment, type IV.~~ When placing ~~type IA~~ geogrid in the embankment foundation, ~~any~~ rutting in the granular material shall not exceed 3 in. ~~in the embankment foundation.~~ The Engineer may increase the lift thickness to obtain stability of the granular material.

REVISION TO SPECIAL PROVISIONS

214-R-733 GEOSYNTHETICS

~~If required by the Engineer, the geogrid material supplier shall provide a qualified manufacturer's representative on the contract site at the start of the work to assist the Contractor. The representative shall also be available during the construction when required by the Engineer or the Contractor.~~

~~When type IB geogrid is used specified for subgrade, proofrolling shall be performed in accordance with 203.26 prior to placing the type IB geogrid. Deflection or rutting shall not exceed 1 in. Any defect shall be repaired as directed. The first 6 in. of coarse aggregate No. 53 shall be spread and compacted with a 10 t roller in static mode. The spreading and compaction of the aggregate shall be performed so that adequate interlocking of the aggregate and geogrid is obtained. The second 6 in. of coarse aggregate No. 53 shall be constructed in accordance with 301.~~

When geogrid is specified for subbase or base applications, geogrid shall be placed as shown on the plans and in accordance with the manufacturer's guidelines.

When specified, the geogrid material supplier shall provide a qualified manufacturer's representative on site at the start of the work to assist the Contractor. The representative shall also be available during the construction when requested by the Engineer or the Contractor.

The geogrid shall be overlapped a minimum of 2 ft side to side and end to end for *subgrade, subbase, and base applications* ~~type IB~~. ~~The type IA g~~Geogrids shall be overlapped 3 ft in areas where foundation conditions cannot support foot traffic or where 2 ft is found to be inadequate during fill placement. Overlaps shall be oriented in the direction of fill placement, or shingled, to prevent advancing fill from lifting any geogrid roll edges. Overlaps shall be further secured to prevent separation during fill placement. Damaged geogrid shall be patched. Patching shall include placement of a minimum of 3 ft of overlapped geogrid beyond the damaged area. If the damaged portion extends for more than 50% of the roll in the width direction, the entire width shall be replaced.

Geogrid shall be covered with fill within three calendar days after placement. Only that amount of geogrid required for pending work shall be placed to minimize exposure of the geogrid.

(d) Geocell Confinement System

The Contractor shall construct the grade in accordance with 203. A layer of geotextile shall be placed in accordance with 214.03(b) and shall be anchored at the roadway edge when widening or when intersecting an existing roadway. The geocell confinement system, GCS, shall be placed and anchored as shown on the plans, or as directed. The Contractor shall ensure that the GCS is anchored vertically and the geocell shall be filled with a minimum of 34 in. of coarse aggregate No. 5, No. 8, or No. 43. If the Contractor chooses No. 5 or No. 8, geotextile in accordance with 918.02(a), Type 1B shall be placed on the GCS before placing No. 53 or No. 73. The GCS shall be oriented with the

REVISION TO SPECIAL PROVISIONS

214-R-733 GEOSYNTHETICS

smaller cell dimension perpendicular to the roadway. The remaining GCS shall be filled with ~~No. 53 or No. 73~~ and at least 98 in. of No. 53 or No. 73. ~~shall be placed on the GCS.~~ The aggregate shall be back dumped and compacted with a light roller in accordance with 301. No trucks or construction vehicles ~~shall~~ will be allowed on the GCS. A light tracked bulldozer or other equipment may be used as directed. ~~The~~ 6 in. lift above GCS shall be compacted with low frequency and amplitude, with a minimum of six passes. The remaining aggregate shall be placed and compacted lightly at first, then with high amplitude. Efforts shall be made to ensure that the geotextile and GCS are in tension. ~~The Contractor may propose an alternate means of providing a typical section for the GCS, and shall submit the proposal to the Engineer for review and approval. The proposal shall be certified by a professional engineer licensed in the State of Indiana.~~

The Contractor may propose an alternate means of providing a typical section for the GCS, and shall submit the proposal to the Engineer for review and approval. The proposal shall be certified by a professional engineer registered in the State of Indiana.

GCS shall be constructed in accordance with 207 and 214.

214.04 Fill Placement

Construction vehicles ~~shall~~ will not be *allowed* on the ~~geogrid~~ geosynthetic. The placement of the fill shall proceed forward along the roadway centerline and outward to the embankment edges and compacted in accordance with 203.23. The Engineer may waive density requirements for the first lift of embankment foundation treatment if the fill is determined to be too weak to support compaction equipment.

214.05 Method of Measurement

Geotextile for pavement, ~~and~~ subgrade, *embankment, and moisture management* will be measured by the square yard, for the type specified. Geotextile for coarse aggregate and drainage blankets will be measured in accordance with 301 and 616, respectively. Geogrid will be measured by the square yard, for the type specified. The quantity will be computed based on the total area of geosynthetics shown on the plans. The aggregate used for the embankment foundation improvement will be measured in accordance with 301.09. The geogrid reinforced subgrade, *GCS, and the excavation required to place the GCS* will be measured in accordance with 207.05.

~~The GCS and the excavation required to place the GCS will not be measured.~~

214.06 Basis of Payment

The accepted quantity of geotextile will be paid for at the contract unit price per square yard per type of geotextile. *Geotextile for subgrade and geotextile for embankment will be paid for as geotextile for pavement, for the type specified, at the contract unit price per square yard.* The accepted quantities of geogrid will be paid for at the contract unit price per square yard per type of geogrid. The aggregates will be paid for in accordance with 301.10. The geogrid reinforced subgrade will be paid for in accordance with 207.06.

REVISION TO SPECIAL PROVISIONS

214-R-733 GEOSYNTHETICS

Payment will be made under:

Pay Item	Pay Unit Symbol
<i>Geotextile for Moisture Management, _____</i>	<i>SYS</i>
<i>type</i>	
Geotextile for Pavement, _____	SYS
type	
Geotextile for Subgrade, _____	SYS
type	
Geogrid, _____	SYS
type	

The cost of furnishing the materials, manufacturer’s representative, all labor and equipment required for furnishing and placing the geotextile or geogrid, all work necessary to establish grades, geogrid splices, overlaps, stakes or pins, supplemental product test data, and patching or replacement of damaged geotextile or geogrid shall be included in the cost of this work.

The geocell confinement system, anchors, restraint clips, pins, necessary incidentals required to provide a complete in place system, and the Type IB geotextile if required for the GCS, shall be included in the cost of subgrade treatment in accordance with 207.06.

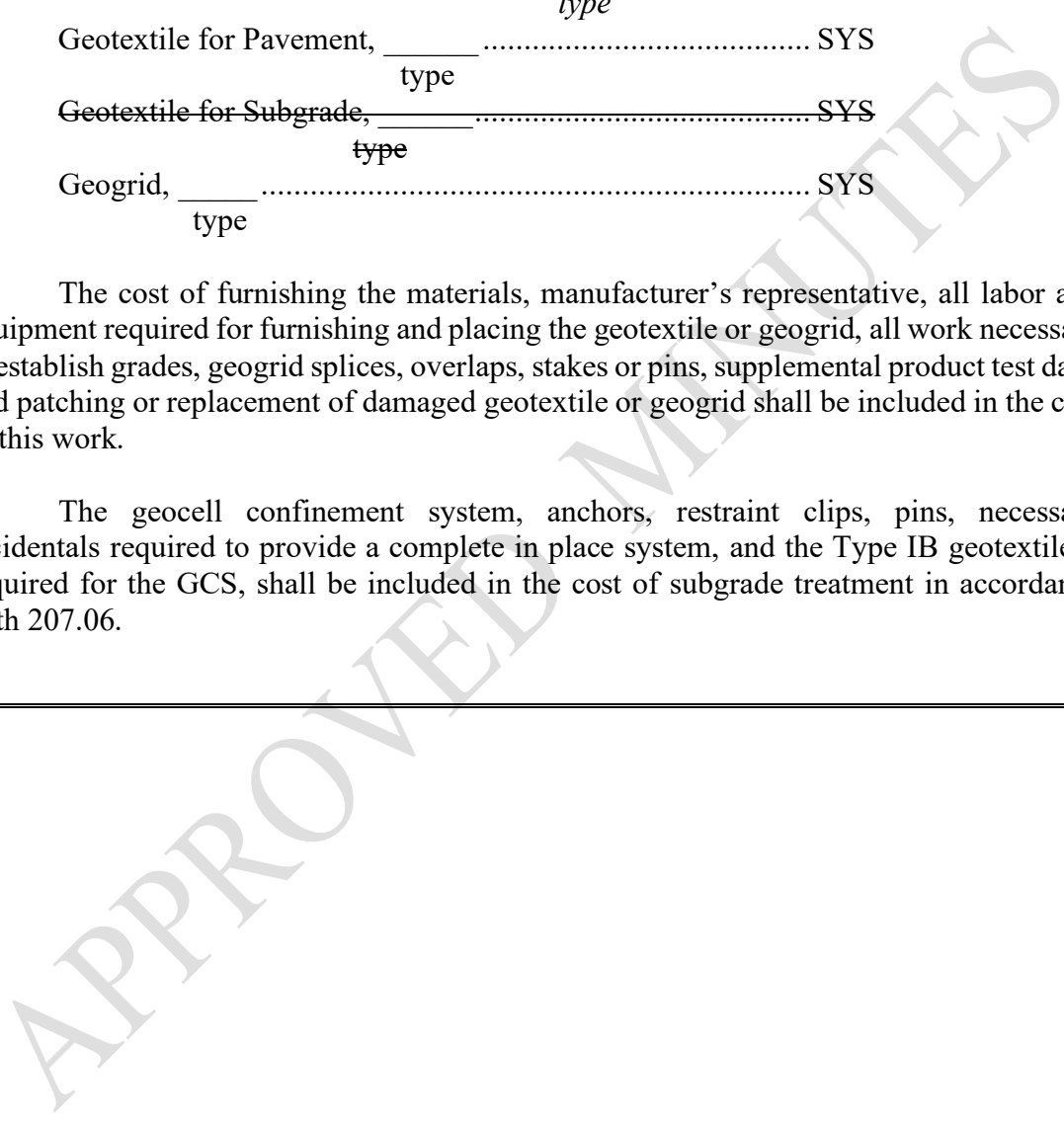

COMMENTS AND ACTION

214-R-733 GEOSYNTHETICS

DISCUSSION:

Mr. Reilman introduced and presented this item, and stated that changes were made to the 214 geotextiles section, and RSP 214-R-733 was created and becomes effective with December lettings. There is confusion because there are references to geotextile for subgrade and geotextile for embankment in the standard drawings but no pay items for these items.

Mr. Reilman proposed, that since both geotextile for subgrade and geotextile for embankment use the same material as geotextile for pavement, we can add a sentence to the Basis of Payment section of RSP 214-R-733 as shown in the item above.

There was no discussion, comments or questions, and this item passed as submitted.

Motion: Mr. Reilman Second: Mr. Dave Ayes: 10 Nays: 0 FHWA Approval: YES	Action: <input checked="" type="checkbox"/> Passed as Submitted <input type="checkbox"/> Passed as Revised <input type="checkbox"/> Withdrawn
Standard Specifications Sections referenced and/or affected: 214 begin pg 241.	<input checked="" type="checkbox"/> 2024 Standard Specifications <input type="checkbox"/> Revise Pay Items List
Recurring Special Provision references in: 214-R-733 GEOSYNTHETICS	<input type="checkbox"/> Create RSP (No. __) Effective: RSP Sunset Date:
Standard Drawing affected: NONE	<input checked="" type="checkbox"/> Revise RSP (No. <u>214-R-733</u>) Effective: <u>March 1, 2022</u> RSP Sunset Date: <u>2024 SS</u>
Design Manual Sections affected: NONE	<input type="checkbox"/> Standard Drawing Effective:
GIFE Sections cross-references: NONE	<input type="checkbox"/> Create RPD (No. __) Effective: <input type="checkbox"/> GIFE Update <input type="checkbox"/> Frequency Manual Update <input type="checkbox"/> SiteManager Update

STANDARD SPECIFICATIONS, SPECIAL PROVISIONS AND STANDARD DRAWINGS
REVISION TO SPECIAL PROVISIONS

PROPOSAL TO THE STANDARDS COMMITTEE

PROBLEM(S) ENCOUNTERED: Unique Special Provisions are intended for a single use on a specific contract for a specific situation on the contract that is not already covered by the Standard Specification or a Special Provision. However, some USPs have been utilized quite frequently on numerous contracts, and have become somewhat “standard”.

PROPOSED SOLUTION: The proposed solution for this USP is to convert it to a Recurring Special Provision in order to expedite the process of implementing this Special Provision into future contracts, while eliminating the need for further review.

APPLICABLE STANDARD SPECIFICATIONS: 604.

APPLICABLE STANDARD DRAWINGS:

APPLICABLE DESIGN MANUAL SECTION:

APPLICABLE SECTION OF GIFE:

APPLICABLE RECURRING SPECIAL PROVISIONS:

PAY ITEMS AFFECTED: None

APPLICABLE SUB-COMMITTEE ENDORSEMENT: Scott Trammell, Construction Specifications Engineer, and the USP Review Process, et al.

IF APPROVED AS A RECURRING SPECIAL PROVISION, THE BASIS FOR USE IS: As determined necessary by the Project Designer.

IMPACT ANALYSIS (attach report): Yes

Submitted By: John Wooden

Title: Estimating Administrator

Organization: Contract Administration

Phone Number: 317-233-5743

Date: September 16, 2021

STANDARD SPECIFICATIONS, SPECIAL PROVISIONS AND STANDARD DRAWINGS
REVISION TO SPECIAL PROVISIONS

IMPACT ANALYSIS REPORT CHECKLIST

Explain the business case as to why this item should be presented to the Standards Committee for approval. Answer the following questions with Yes, No or N/A.

Does this item appear in any other specification sections? Yes, several.

Will approval of this item affect the Approved Materials List? No

Will this proposal improve:

Construction costs? Yes

Construction time? Yes

Customer satisfaction? Yes

Congestion/travel time? Yes

Ride quality? N/A

Will this proposal reduce operational costs or maintenance effort? Yes

Will this item improve safety:

For motorists? Yes

For construction workers? Yes

Will this proposal improve quality for:

Construction procedures/processes? Yes

Asset preservation? Yes

Design process? Maybe

Will this change provide the contractor more flexibility? Yes

Will this proposal provide clarification for the Contractor and field personnel? Yes

Can this item improve/reduce the number of potential change orders? Yes

Is this proposal needed for compliance with:

Federal or State regulations? Yes

AASHTO or other design code? N/A

Is this item editorial? No

Provide any further information as to why this proposal should be placed on the Standards Committee meeting Agenda: For ease of use for implementation and to improve the USP Review Process flow capacity.

REVISION TO SPECIAL PROVISIONS

xxx-x-xxx TEMPORARY CURB RAMP (proposed new)

801-x-xxx TEMPORARY CURB RAMP

(Adopted xx-xx-21)

Description

This work shall consist of installing temporary curb ramps for temporary pedestrian access at various intersections in accordance with 105.03.

Materials

Materials shall be in accordance with 604.02 and as needed.

Construction Requirements

The Contractor shall place temporary curb ramps to provide ADA compliant temporary access for pedestrians in accordance with 107.08 and as shown on the plans.

The ramps shall be a minimum of 48 in. wide and have a slip resistant surface. The ramp shall not have a greater than an 8% longitudinal slope or 1.5% cross slope.

The temporary ramp shall have edge support to help provide guidance for mobility aids.

The temporary ramp can be placed perpendicular or parallel to curb if adequate room is available. If the ramp is placed parallel to curb a minimum of a 48 in. by 48 in. turn space shall be provided at each required turn location. The turn space shall have a cross slope and running slope 2% or less.

The temporary curb ramp shall be kept free of any obstructions or trip hazards including debris, mud, construction equipment, and stored materials.

The Contractor shall submit the manufacturer's technical data, specifications and installation instructions for the temporary curb ramp to the Engineer for approval.

The final layout of the temporary curb ramp at each location shall be as approved by the Engineer prior to closing the existing sidewalk.

Method of Measurement

Temporary curb ramp will be measured by the number of units installed, maintained, and removed.

Basis of Payment

The accepted quantity of temporary curb ramps will be paid for at the contract unit price per each.

Payment will be made under:

Pay Item Pay

Unit Symbol

REVISION TO SPECIAL PROVISIONS

xxx-x-xxx TEMPORARY CURB RAMP (proposed new)

Temporary Curb Ramp.....EACH

The cost of all labor, materials, equipment and all necessary incidentals required to place the temporary curb ramps during construction operations and removal of the temporary curb ramps after construction is complete shall be included in the cost of the temporary curb ramp.

APPROVED MINUTES

COMMENTS AND ACTION

xxx-x-xxx TEMPORARY CURB RAMP

DISCUSSION:

Mr. Wooden introduced and presented this item stating that Unique Special Provisions are intended for a single use on a specific contract for a specific situation on the contract that is not already covered by the Standard Specification or a Special Provision. However, some USPs have been utilized quite frequently on numerous contracts, and have become somewhat “standard”.

The proposed solution for this USP is to convert it to a Recurring Special Provision in order to expedite the process of implementing this Special Provision into future contracts, while eliminating the need for further review.

Mr. Koch mentioned that the special provision includes a mixture of ADA requirement and INDOT design goals, and asked if we can avoid another set of requirements; 8% longitudinal & 1.5% cross slope? Or perhaps write as a design goal. Ms. Smutzer suggested revising the language stating that vertical discontinuities, slopes, drainage, and zero construction tolerances are covered in 604.03.

Following further detailed discussions, Mr. Wooden withdrew this item. Ms. Smutzer said that she will address this item at the next TAC meeting.

Motion: Mr. Wooden Second: Mr. Boruff Ayes: Nays: FHWA Approval:	Action: <input type="checkbox"/> Passed as Submitted <input type="checkbox"/> Passed as Revised <input checked="" type="checkbox"/> Withdrawn
Standard Specifications Sections referenced and/or affected: 604 begin pg 501. Recurring Special Provision references in: (proposed new) Standard Drawing affected: Design Manual Sections affected: GIFE Sections cross-references:	<input type="checkbox"/> 2024 Standard Specifications <input type="checkbox"/> Revise Pay Items List <input type="checkbox"/> Create RSP (No.) Effective: RSP Sunset Date: <input type="checkbox"/> Revise RSP (No. __) Effective: RSP Sunset Date: <input type="checkbox"/> Standard Drawing Effective: <input type="checkbox"/> Create RPD (No. __) Effective: <input type="checkbox"/> GIFE Update <input type="checkbox"/> Frequency Manual Update <input type="checkbox"/> SiteManager Update

STANDARD SPECIFICATIONS, SPECIAL PROVISIONS AND STANDARD DRAWINGS
REVISION TO SPECIAL PROVISIONS

PROPOSAL TO THE STANDARDS COMMITTEE

PROBLEM(S) ENCOUNTERED: Unique Special Provisions are intended for a single use on a specific contract for a specific situation on the contract that is not already covered by the Standard Specification or a Special Provision. However, some USPs have been utilized quite frequently on numerous contracts, and have become somewhat “standard”.

PROPOSED SOLUTION: The proposed solution for this USP is to convert it to a Recurring Special Provision in order to expedite the process of implementing this Special Provision into future contracts, while eliminating the need for further review.

APPLICABLE STANDARD SPECIFICATIONS: 203, and 206.

APPLICABLE STANDARD DRAWINGS:

APPLICABLE DESIGN MANUAL SECTION:

APPLICABLE SECTION OF GIFE:

APPLICABLE RECURRING SPECIAL PROVISIONS:

PAY ITEMS AFFECTED: None

APPLICABLE SUB-COMMITTEE ENDORSEMENT: Scott Trammell, Construction Specifications Engineer, and the USP Review Process, et al.

IF APPROVED AS A RECURRING SPECIAL PROVISION, THE BASIS FOR USE IS: As determined necessary by the Project Designer.

IMPACT ANALYSIS (attach report): Yes

Submitted By: John Wooden

Title: Estimating Administrator

Organization: Contract Administration

Phone Number: 317-233-5743

Date: September 16, 2021

STANDARD SPECIFICATIONS, SPECIAL PROVISIONS AND STANDARD DRAWINGS
REVISION TO SPECIAL PROVISIONS

IMPACT ANALYSIS REPORT CHECKLIST

Explain the business case as to why this item should be presented to the Standards Committee for approval. Answer the following questions with Yes, No or N/A.

Does this item appear in any other specification sections? Yes, several.

Will approval of this item affect the Approved Materials List? No

Will this proposal improve:

Construction costs? Yes

Construction time? Yes

Customer satisfaction? Yes

Congestion/travel time? Yes

Ride quality? N/A

Will this proposal reduce operational costs or maintenance effort? Yes

Will this item improve safety:

For motorists? Yes

For construction workers? Yes

Will this proposal improve quality for:

Construction procedures/processes? Yes

Asset preservation? Yes

Design process? Maybe

Will this change provide the contractor more flexibility? Yes

Will this proposal provide clarification for the Contractor and field personnel? Yes

Can this item improve/reduce the number of potential change orders? Yes

Is this proposal needed for compliance with:

Federal or State regulations? Yes

AASHTO or other design code? N/A

Is this item editorial? No

Provide any further information as to why this proposal should be placed on the Standards Committee meeting Agenda: For ease of use for implementation and to improve the USP Review Process flow capacity.

REVISION TO SPECIAL PROVISIONS

xxx-x-xxx TEMPORARY SHORING (proposed new)

xxx-x-xxx TEMPORARY SHORING

(Adopted xx-xx-21)

Description

This work shall consist of constructing temporary shoring, as specified, in accordance with 105.03.

Materials

Materials shall be in accordance with 712.02, 734.03, and 735.05.

Construction Requirements

Construction and placement shall be in accordance with 203. The Contractor shall submit working drawings and design computations for the temporary shoring in accordance with 105.02. No removal of the existing excavation shall be performed until the working drawings are approved by the Engineer.

Method of Measurement

Temporary shoring will not be measured for payment.

Basis of Payment

Temporary shoring will be paid for at the contract unit price per lump sum.

Payment will be made under:

Pay Item	Pay Unit Symbol
Temporary Shoring.....	LS

The cost for construction, working drawings, structural analysis, placement, excavation, materials, and all other incidentals shall be included in the cost of temporary shoring.

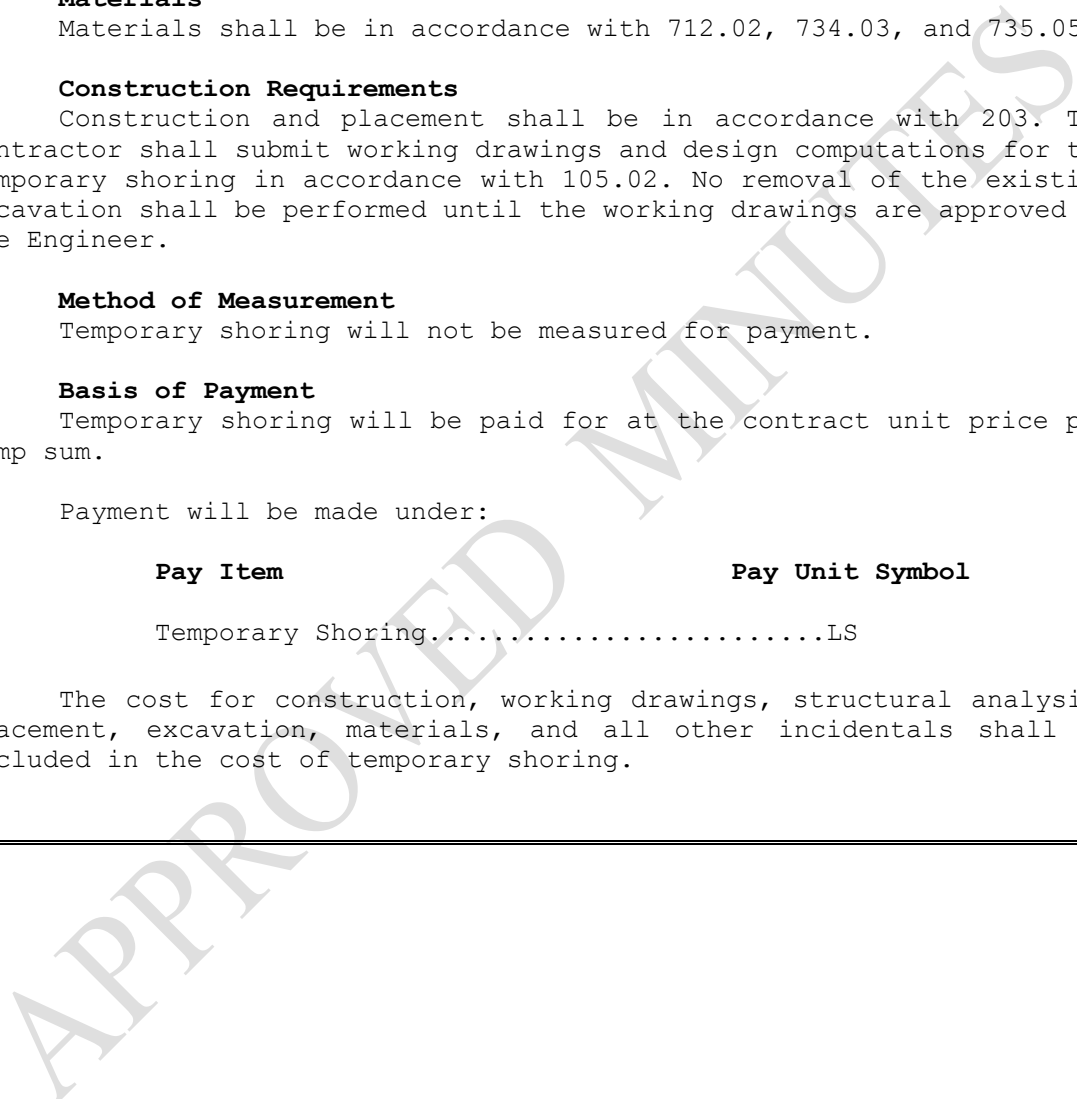

COMMENTS AND ACTION

xxx-x-xxx TEMPORARY SHORING

DISCUSSION:

Mr. Wooden introduced and presented this item stating that Unique Special Provisions are intended for a single use on a specific contract for a specific situation on the contract that is not already covered by the Standard Specification or a Special Provision. However, some USPs have been utilized quite frequently on numerous contracts, and have become somewhat “standard”.

The proposed solution for this USP is to convert it to a Recurring Special Provision in order to expedite the process of implementing this Special Provision into future contracts, while eliminating the need for further review.

Mr. White believes this USP could use some additional guidance. Mr. Wooden concurred and withdrew this item pending further review.

Motion: Mr. Wooden Second: Mr. Ayes: Nays: FHWA Approval:	Action: <input type="checkbox"/> Passed as Submitted <input type="checkbox"/> Passed as Revised <input checked="" type="checkbox"/> Withdrawn
Standard Specifications Sections referenced and/or affected: 203 and 206.	<input type="checkbox"/> 2024 Standard Specifications <input type="checkbox"/> Revise Pay Items List
Recurring Special Provision references in: (proposed new)	<input type="checkbox"/> Create RSP (No.) Effective: RSP Sunset Date:
Standard Drawing affected: Design Manual Sections affected:	<input type="checkbox"/> Revise RSP (No. __) Effective: RSP Sunset Date:
GIFE Sections cross-references:	<input type="checkbox"/> Standard Drawing Effective: <input type="checkbox"/> Create RPD (No. __) Effective: <input type="checkbox"/> GIFE Update <input type="checkbox"/> Frequency Manual Update <input type="checkbox"/> SiteManager Update

STANDARD SPECIFICATIONS, SPECIAL PROVISIONS AND STANDARD DRAWINGS
REVISION TO SPECIAL PROVISIONS

PROPOSAL TO THE STANDARDS COMMITTEE

PROBLEM(S) ENCOUNTERED: Unique Special Provisions are intended for a single use on a specific contract for a specific situation on the contract that is not already covered by the Standard Specification or a Special Provision. However, some USPs have been utilized quite frequently on numerous contracts, and have become somewhat “standard”.

PROPOSED SOLUTION: The proposed solution for this USP is to convert it to a Recurring Special Provision in order to expedite the process of implementing this Special Provision into future contracts, while eliminating the need for further review.

APPLICABLE STANDARD SPECIFICATIONS: 801.

APPLICABLE STANDARD DRAWINGS:

APPLICABLE DESIGN MANUAL SECTION:

APPLICABLE SECTION OF GIFE:

APPLICABLE RECURRING SPECIAL PROVISIONS:

PAY ITEMS AFFECTED: None

APPLICABLE SUB-COMMITTEE ENDORSEMENT: Scott Trammell, Construction Specifications Engineer, and the USP Review Process, et al.

IF APPROVED AS A RECURRING SPECIAL PROVISION, THE BASIS FOR USE IS: As determined necessary by the Project Designer.

IMPACT ANALYSIS (attach report): Yes

Submitted By: John Wooden

Title: Estimating Administrator

Organization: Contract Administration

Phone Number: 317-233-5743

Date: September 16, 2021

STANDARD SPECIFICATIONS, SPECIAL PROVISIONS AND STANDARD DRAWINGS
REVISION TO SPECIAL PROVISIONS

IMPACT ANALYSIS REPORT CHECKLIST

Explain the business case as to why this item should be presented to the Standards Committee for approval. Answer the following questions with Yes, No or N/A.

Does this item appear in any other specification sections? Yes, several.

Will approval of this item affect the Approved Materials List? No

Will this proposal improve:

Construction costs? Yes

Construction time? Yes

Customer satisfaction? Yes

Congestion/travel time? Yes

Ride quality? N/A

Will this proposal reduce operational costs or maintenance effort? Yes

Will this item improve safety:

For motorists? Yes

For construction workers? Yes

Will this proposal improve quality for:

Construction procedures/processes? Yes

Asset preservation? Yes

Design process? Maybe

Will this change provide the contractor more flexibility? Yes

Will this proposal provide clarification for the Contractor and field personnel? Yes

Can this item improve/reduce the number of potential change orders? Yes

Is this proposal needed for compliance with:

Federal or State regulations? Yes

AASHTO or other design code? N/A

Is this item editorial? No

Provide any further information as to why this proposal should be placed on the Standards Committee meeting Agenda: For ease of use for implementation and to improve the USP Review Process flow capacity.

REVISION TO SPECIAL PROVISIONS

xxx-x-xxx TEMPORARY WORKSITE SPEED DISPLAY (proposed new)

801-R-xxx TEMPORARY WORKSITE SPEED DISPLAY

(Adopted xx-xx-21)

Description

This work shall consist of furnishing and installing solar powered, temporary worksite speed display assembly, at the locations shown on the plans or where directed by the Engineer, in accordance with 105.03.

Materials

Materials shall be in accordance with 801.02, and the Indiana Manual on Uniform Traffic Control Devices, MUTCD. The temporary worksite speed display assembly shall be an all-weather, self-contained unit. The signs shall be installed on a mounted moveable stand or trailers in accordance with 910.14(f).

Construction Requirements

Each temporary worksite speed display assembly shall be installed in accordance with 801.15(c) and the manufacturer recommendations. Each unit installed shall consist of a driver speed feedback display sign and text that reads "YOUR SPEED." Each temporary worksite speed display assembly shall require solar power and be normally dark. The display shall be illuminated and have reflective properties for day readability and automatic dimming for nighttime readability.

The display shall have a minimum numeral height of 10 in. and use yellow LED bulbs to display driver speed. The display shall be clearly readable at a distance of 325 ft. The unit shall monitor traffic for advancing vehicles via radar and shall be programmable for the posted speed limit and threshold speed. The threshold speed shall be set at 10 mph above the posted speed for roadways with speeds under 45 mph and at 20 mph above the posted speed for roadways with speeds 45 mph or greater. The sign shall activate when the speed limit of the roadway is exceeded by one mph and flash the driver speed at a rate of 50 cycles per minute. When the detected speed exceeds the threshold speed the display shall go dark.

Method of Measurement

Temporary worksite speed display assemblies will be measured by the number of units installed.

Basis of Payment

Temporary worksite speed display assemblies will be paid for at the contract unit price per each.

Payment will be made under:

Pay Item

Pay Unit Symbol

Temporary Worksite Speed Display Assembly....EACH

REVISION TO SPECIAL PROVISIONS

xxx-x-xxx TEMPORARY WORKSITE SPEED DISPLAY (proposed new)

The cost of materials, transportation, placement, and all incidentals to provide a working temporary worksite speed display assembly shall be included in the cost of the pay item.

APPROVED MINUTES

COMMENTS AND ACTION

xxx-x-xxx TEMPORARY WORKSITE SPEED DISPLAY

DISCUSSION:

Mr. Wooden introduced and presented this item stating that Unique Special Provisions are intended for a single use on a specific contract for a specific situation on the contract that is not already covered by the Standard Specification or a Special Provision. However, some USPs have been utilized quite frequently on numerous contracts, and have become somewhat “standard”.

The proposed solution for this USP is to convert it to a Recurring Special Provision in order to expedite the process of implementing this Special Provision into future contracts, while eliminating the need for further review.

Mr. Wooden withdrew this item pending further review from Traffic Administration who will investigate if this can be eventually become part of the Standard Specifications.

Motion: Mr. Wooden Second: Mr. Ayes: Nays: FHWA Approval:	Action: ___ Passed as Submitted ___ Passed as Revised <u>X</u> Withdrawn
Standard Specifications Sections referenced and/or affected:	___ 2024 Standard Specifications
801 begin pg 863.	___ Revise Pay Items List
Recurring Special Provision references in: (proposed new)	___ Create RSP (No.) Effective: RSP Sunset Date:
Standard Drawing affected:	___ Revise RSP (No. ___) Effective:
Design Manual Sections affected:	___ RSP Sunset Date:
GIFE Sections cross-references:	___ Standard Drawing Effective:
	___ Create RPD (No. ___) Effective:
	___ GIFE Update
	___ Frequency Manual Update
	___ SiteManager Update

STANDARD SPECIFICATIONS, SPECIAL PROVISIONS AND STANDARD DRAWINGS
REVISION TO SPECIAL PROVISIONS

PROPOSAL TO THE STANDARDS COMMITTEE

PROBLEM(S) ENCOUNTERED: Unique Special Provisions are intended for a single use on a specific contract for a specific situation on the contract that is not already covered by the Standard Specification or a Special Provision. However, some USPs have been utilized quite frequently on numerous contracts, and have become somewhat “standard”.

PROPOSED SOLUTION: The proposed solution for this USP is to convert it to a Recurring Special Provision in order to expedite the process of implementing this Special Provision into future contracts, while eliminating the need for further review.

APPLICABLE STANDARD SPECIFICATIONS: 714, and 723.

APPLICABLE STANDARD DRAWINGS:

APPLICABLE DESIGN MANUAL SECTION:

APPLICABLE SECTION OF GIFE:

APPLICABLE RECURRING SPECIAL PROVISIONS:

PAY ITEMS AFFECTED: None

APPLICABLE SUB-COMMITTEE ENDORSEMENT: Scott Trammell, Construction Specifications Engineer, and the USP Review Process, et al.

IF APPROVED AS A RECURRING SPECIAL PROVISION, THE BASIS FOR USE IS: As determined necessary by the Project Designer.

IMPACT ANALYSIS (attach report): Yes

Submitted By: John Wooden

Title: Estimating Administrator

Organization: Contract Administration

Phone Number: 317-233-5743

Date: September 16, 2021

STANDARD SPECIFICATIONS, SPECIAL PROVISIONS AND STANDARD DRAWINGS
REVISION TO SPECIAL PROVISIONS

IMPACT ANALYSIS REPORT CHECKLIST

Explain the business case as to why this item should be presented to the Standards Committee for approval. Answer the following questions with Yes, No or N/A.

Does this item appear in any other specification sections? Yes, several.

Will approval of this item affect the Approved Materials List? No

Will this proposal improve:

Construction costs? Yes

Construction time? Yes

Customer satisfaction? Yes

Congestion/travel time? Yes

Ride quality? N/A

Will this proposal reduce operational costs or maintenance effort? Yes

Will this item improve safety:

For motorists? Yes

For construction workers? Yes

Will this proposal improve quality for:

Construction procedures/processes? Yes

Asset preservation? Yes

Design process? Maybe

Will this change provide the contractor more flexibility? Yes

Will this proposal provide clarification for the Contractor and field personnel? Yes

Can this item improve/reduce the number of potential change orders? Yes

Is this proposal needed for compliance with:

Federal or State regulations? Yes

AASHTO or other design code? N/A

Is this item editorial? No

Provide any further information as to why this proposal should be placed on the Standards Committee meeting Agenda: For ease of use for implementation and to improve the USP Review Process flow capacity.

REVISION TO SPECIAL PROVISIONS

xxx-x-xxx WATERPROOFING MEMBRANE FOR REINFORCED-CONCRETE BOX STRUCTURES
AND THREE-SIDED STRUCTURES (proposed new)

xxx-x-xxx WATERPROOFING MEMBRANE FOR REINFORCED-CONCRETE BOX STRUCTURES
AND THREE-SIDED STRUCTURES

(Adopted xx-xx-21)

The Standard Specifications are revised as follows:

SECTION 714, AFTER LINE 20, INSERT AS FOLLOWS:

Fabric or Membrane for Waterproofing 918.06

SECTION 714, BEGIN LINE 347, DELETE AND INSERT AS FOLLOWS:

714.10 Precast Reinforced Concrete Box Structure Section Joints

Precast reinforced concrete box structure section joints shall be sealed as shown on the plans. Pipe joint sealant shall be applied once the concrete surface temperature is above 40°F or above the minimum application temperature recommended by the pipe joint sealant manufacturer. The concrete surfaces shall be clean and dry prior to application of the pipe joint sealant. Heat may be applied to the concrete surfaces until they are in accordance with the temperature and dryness requirements. ~~The pipe joint sealant shall be centered on both sides of the joint as it is being applied.~~ *The pipe joint sealant shall be applied to the bell or spigot section of the structure and applied prior to joining segments. The volume of pipe joint sealant applied shall be in accordance with the manufacturer's recommendations.*

*Joints shall be covered by a geotextile joint sealer system or joint membrane in accordance with 907.07 unless a waterproofing membrane is shown on the plans. The sealer system or joint membrane shall be centered across the joint and applied in accordance with the manufacturer's recommendations and the following. After application, the geotextile or membrane material shall be rolled to avoid wrinkling. If the roll of geotextile or membrane material does not cover the full length of the joint, ~~an overlap of at least 2 1/2 in. will be required to start the next roll of material.~~ *the next roll of material shall overlap a minimum of 3 in.* The manufacturer's application instructions shall apply in addition to the above requirements.*

714.11 Waterproofing Membrane

Where a waterproofing membrane is shown on the plans, joints, exterior vertical surfaces, and the exterior top horizontal surface shall be covered in their entirety with the membrane. A Type 2 waterproofing membrane shall be installed on all exterior vertical surfaces and on the top exterior horizontal surface that will not have asphalt placed directly the membrane. A Type 3 waterproofing membrane shall be installed on the top horizontal surface when asphalt will be placed directly on the membrane.

(a) Preparation

Concrete surfaces shall be prepared in accordance with the membrane manufacturer's recommendations and the following. Concrete surfaces shall be smooth and free from projections and holes. All sharp edges and metal protrusions shall be ground

REVISION TO SPECIAL PROVISIONS

xxx-x-xxx WATERPROOFING MEMBRANE FOR REINFORCED-CONCRETE BOX STRUCTURES
AND THREE-SIDED STRUCTURES (proposed new)

smooth. Immediately prior to application, the surface shall be dry and free of dust and loose materials. All joints and exterior corners shall be prepared in accordance with the membrane manufacturer's recommendations.

Prior to installing a Type 2 membrane a prime coat recommended by the waterproofing membrane manufacturer shall be applied to all exterior surfaces. Membranes shall be installed when ambient temperature is 40°F or above, unless lower temperatures are allowed in accordance with the membrane manufacturer's recommendations.

Prior to installing a Type 3 membrane, the ambient air temperature shall be 40°F or above. The surface shall be dry enough to prevent the formation of steam when the hot-applied primer coat is applied.

(b) Installation

The waterproofing membrane shall be installed prior to be backfilling.

Coating and fabric shall stop a uniform distance below the top surfaces of walls. The material shall not be splattered over surfaces or faces of concrete which subsequently are exposed in the finished structure. The membrane shall be placed in V-strips at the joints to allow the movement of adjacent sections of concrete without tearing the fabric. The membrane shall be flashed at all exposed edges and laps sealed down. The membrane shall not be damaged when backfill is placed. On structures with curbs, the waterproofing membrane shall be placed 3 in. up the curb face and the edge of the membrane shall be sealed in accordance with the membrane manufacturer's recommendations.

For a Type 2 waterproofing membrane, the release liner shall be removed, and the adhesive side shall be placed on the prepared concrete surface. After application, the membrane material shall be rolled to avoid wrinkling and ensure adhesion of the membrane to the concrete.

For a Type 3 membrane waterproofing, the primer coat shall be applied no farther than 5 ft in front of the membrane, using a squeegee to fill all voids and imperfections. The membrane shall be applied from the low to the high side of the surface. An extra bead of primer shall be applied at the edge of the membrane. After installing the membrane over the entire surface, all joints in the membrane shall be sealed by applying primer and smoothing with a V-squeegee. Tack coat, in accordance with 406, shall be applied to a Type 3 waterproofing membrane, without damaging the membrane, before placing any asphalt pavement.

For membrane material that does not cover the surface, an overlap of at least 3 in. shall be required on all edges. The Type 2 or Type 3 waterproofing membrane from the top horizontal surface shall overlap the membrane on the vertical surfaces on the outside by

REVISION TO SPECIAL PROVISIONS

xxx-x-xxx WATERPROOFING MEMBRANE FOR REINFORCED-CONCRETE BOX STRUCTURES AND THREE-SIDED STRUCTURES (proposed new)

at least 12 in. The manufacturer's application instructions shall apply in addition to the above requirements.

SECTION 714, BEGIN LINE 351, DELETE AND INSERT AS FOLLOWS:

714.112 Method of Measurement

SECTION 714, BEGIN LINE 379, DELETE AND INSERT AS FOLLOWS:

714.123 Basis of Payment

SECTION 714, BEGIN LINE 412, INSERT AS FOLLOWS:

The cost of excavation except as provided in 206.11(a), expansion joint material, perpetuation of existing drains shown on the plans, removal of portions of existing structures, cleaning out old channels or structures, *waterproofing membrane*, chemical anchor system, precast reinforced concrete structure joints, and necessary incidentals shall be included in the cost of the structure or structure extension.

SECTION 723, AFTER LINE 24, INSERT AS FOLLOWS:

Fabric or Membrane for Waterproofing..... 918.06

SECTION 723, BEGIN LINE 89, DELETE AND INSERT AS FOLLOWS:

723.03 General Requirements

Excavation and disposal shall be in accordance with the applicable requirements of 206. ~~The areas designated for waterproofing shall be waterproofed in accordance with 702.23~~ *Waterproofing membranes shall be in accordance with 714.11.* All underground drains encountered during excavation for the structure shall be perpetuated as dictated by field conditions. Drainage openings through masonry shall be in accordance with 702.16. Handling of three-sided structures shall be in accordance with 907.05. Handling of wingwalls and spandrel walls shall be in accordance with 907.06.

SECTION 723, BEGIN LINE 395, INSERT AS FOLLOWS:

723.14 Joints

Joints between structure sections for three-sided arch-topped structures and true arch shape structures, and for flat-topped structures with cover of 3 ft or more, may be either butt joints or keyway joints.

The sections of flat-topped structures with less than 3 ft of cover shall be produced with a minimum 4 in. depth by 1 1/2 in. width keyway joint. Non-shrink grout in accordance with 707.09 shall be placed in the keyway joint.

All butt joints between structure sections shall be covered with a joint wrap in accordance with ASTM C877 *unless a waterproofing membrane is shown on the plans.* The surface shall be free of dirt before the joint material is applied. The entire joint shall be continuously covered. *When shown on the plans, all joints, exterior vertical surfaces, and exterior top surfaces shall be covered in their entirety with an external waterproofing*

REVISION TO SPECIAL PROVISIONS

 xxx-x-xxx WATERPROOFING MEMBRANE FOR REINFORCED-CONCRETE BOX STRUCTURES
 AND THREE-SIDED STRUCTURES (proposed new)

membrane in accordance with 714.11.

Joints between structure sections and wingwalls, between wingwalls and spandrel walls, and between structure sections and headwalls or spandrel walls shall be covered with either the same wrap used between structure sections or with geotextile in accordance with 918.02.

SECTION 723, BEGIN LINE 417, INSERT AS FOLLOWS:

723.15 Backfilling

Waterproofing membrane shall be applied prior to backfilling.

Structure backfill shall be placed and compacted in accordance with 211. Structure backfill shall be placed and compacted on each side of the structure to the fill line shown on the plans. During the backfill operation, the difference in elevations of the fill on each side of the structure shall not exceed 24 in.

SECTION 723, BEGIN LINE 502, INSERT AS FOLLOWS:

The cost of all design, coring, testing, pedestals or extended legs, excavation, repairs, plugging core and handling holes, mortar, grout, sealer, *waterproofing membrane*, cylinder molds, and necessary incidentals shall be included in the cost of the structure or structure extension.

The cost of spandrel walls, concrete base slab, footings, and aggregate base under footings shall be included in the cost of the structure or structure extension.

SECTION 918, BEGIN LINE 126, DELETE AND INSERT AS FOLLOWS:

918.06 Fabric or Membrane for Waterproofing

~~Fabric for~~ *Type 1 waterproofing shall consist of a Utility Asphalt, UA-1 in accordance with 902.01(d) and a fabric consisting of treated cotton in accordance with ASTM D173, woven glass in accordance with ASTM D1668, or glass fiber mat in accordance with ASTM D2178. A type C certification in accordance with 916 shall be provided for the fabric.*

Type 2 waterproofing shall consist of a rubberized asphalt and peel-and-stick waterproofing membrane. Membrane materials shall be stored indoors and at temperatures not to exceed 120 °F.

<i>PROPERTY</i>	<i>TEST METHOD</i>	<i>REQUIREMENTS</i>
<i>Thickness</i>	<i>ASTM D1777</i>	<i>60 mils, min.</i>
<i>Width</i>		<i>36 in., min.</i>

REVISION TO SPECIAL PROVISIONS

xxx-x-xxx WATERPROOFING MEMBRANE FOR REINFORCED-CONCRETE BOX STRUCTURES
AND THREE-SIDED STRUCTURES (proposed new)

<i>Pliability</i>	<i>ASTM D146</i>	<i>180° bend over 1/4 in. mandrel @ -25 °F with no effect</i>
<i>Elongation</i>	<i>ASTM D412 (Die C)</i>	<i>300%, min.</i>
<i>Puncture Resistance – Membrane</i>	<i>ASTM E154</i>	<i>35 lb min.</i>
<i>Permeance ()</i>	<i>ASTM E96, Method B</i>	<i>0.1 grains/sq ft/hr/in Hg, max.</i>
<i>Water Absorption, % by Weight</i>	<i>ASTM D570</i>	<i>0.2, max.</i>
<i>Adhesion to concrete</i>	<i>ASTM D903</i>	<i>5.0, min.</i>

Type 3 waterproofing shall consist of a hot-applied joint primer coat in accordance with ASTM D6690 and a waterproofing membrane consisting of a high-density asphalt mastic between two layers of polymeric fabric. The membrane and primer materials shall be kept dry prior to installation.

<i>PROPERTY</i>	<i>TEST METHOD</i>	<i>REQUIREMENTS</i>
<i>Thickness, min.</i>		<i>0.135 in.</i>
<i>Width, min.</i>		<i>36 in.</i>
<i>Weight, min.</i>		<i>0.8 lb/sq ft</i>
<i>Tensile strength, machine direction</i>	<i>ASTM D882, Modified^[1]</i>	<i>275 lb/in. 2,000 psi</i>
<i>Tensile strength, 90° to machine direction</i>	<i>ASTM D882, Modified^[1]</i>	<i>150 lb/in. 1,000 psi</i>
<i>Elongation at break</i>	<i>ASTM D882, Modified^[1]</i>	<i>100% min.</i>
<i>Brittleness</i>	<i>ASTM D517</i>	<i>Pass</i>
<i>Softening point (mastic)</i>	<i>ASTM D36</i>	<i>200 °F min.</i>
<i>Peel adhesion</i>	<i>ASTM D413^[1]</i>	<i>2.0 lb/in.</i>
<i>Cold flex ()</i>	<i>ASTM D146 2 x 5 inch specimen</i>	<i>180° bend over 2-in. mandrel with no cracking</i>
<i>Heat stability</i>	<i>2 x 5 inch specimen</i>	<i>vertically suspended in a mechanical convection oven 2 hr @ 190 °F with no dripping or delamination</i>
<i>[1] 12 in. per minute test speed and 1 in. initial distance between the grips.</i>		

REVISION TO SPECIAL PROVISIONS

xxx-x-xxx WATERPROOFING MEMBRANE FOR REINFORCED-CONCRETE BOX STRUCTURES
AND THREE-SIDED STRUCTURES (proposed new)

*Type 2 and Type 3 material furnished under this specification shall be covered by
a type B Certification in accordance with 916.*

APPROVED MINUTES

COMMENTS AND ACTION

xxx-x-xxx WATERPROOFING MEMBRANE FOR REINFORCED-CONCRETE BOX STRUCTURES
AND THREE-SIDED STRUCTURES

DISCUSSION:

Mr. Wooden introduced and presented this item stating that Unique Special Provisions are intended for a single use on a specific contract for a specific situation on the contract that is not already covered by the Standard Specification or a Special Provision. However, some USPs have been utilized quite frequently on numerous contracts, and have become somewhat “standard”.

The proposed solution for this USP is to convert it to a Recurring Special Provision in order to expedite the process of implementing this Special Provision into future contracts, while eliminating the need for further review.

Mr. Koch asked about 714.10, prior to the meeting, stating that box pieces are rarely perfectly cast and the joint on the top of a box tends to open, if not careful, due to the excavation of the wingwalls. Some problems have occurred where joints are a bit open without the joint being filled which may cause the membrane to puncture.

Mr. White responded that he understands that pipe joint sealant is always required to be installed on the bell and spigot connection, in accordance with 714.10. When the waterproofing membrane USP is used, the geotextile joint sealer or joint membrane is omitted, because the waterproofing membrane is essentially the same thing.

Following much discussion, Mr. Koch replied that “I believe the proposed RSP is ok, we just may want to clarify our joint sealing expectations on the standards drawings, and that a good contractor would find a way to provide tight joints”. Bottom line is that education is needed in order to provide proper fit and good joints. Mr. White agreed that the standard drawings could use a little work for clarification.

Mr. Reilman stated that some Contractors are having difficulty finding materials to meet those specified, and suggested revising the revisions to 918.06. Mr. White agreed and said we can bring this one back next month.

Therefore, Mr. Wooden withdrew this item.

COMMENTS AND ACTION

xxx-x-xxx WATERPROOFING MEMBRANE FOR REINFORCED-CONCRETE BOX STRUCTURES AND THREE-SIDED STRUCTURES

[continued]

<p>Motion: Mr. Wooden Second: Mr. Ayes: Nays: FHWA Approval:</p>	<p>Action: ___ Passed as Submitted ___ Passed as Revised <u>X</u> Withdrawn</p>
<p>Standard Specifications Sections referenced and/or affected: 714 pg 721; 723 pg 791, and 918.06 pg 1134.</p>	<p>___ 2024 Standard Specifications ___ Revise Pay Items List ___ Create RSP (No.) Effective: RSP Sunset Date:</p>
<p>Recurring Special Provision references in: (proposed new)</p>	<p>___ Revise RSP (No. ___) Effective: RSP Sunset Date:</p>
<p>Standard Drawing affected:</p>	<p>___ Standard Drawing Effective: RSP Sunset Date:</p>
<p>Design Manual Sections affected:</p>	<p>___ Standard Drawing Effective:</p>
<p>GIFE Sections cross-references:</p>	<p>___ Create RPD (No. ___) Effective:</p>
	<p>___ GIFE Update ___ Frequency Manual Update ___ SiteManager Update</p>

STANDARD SPECIFICATIONS, SPECIAL PROVISIONS AND STANDARD DRAWINGS
REVISION TO SPECIAL PROVISIONS

PROPOSAL TO THE STANDARDS COMMITTEE

PROBLEM(S) ENCOUNTERED: Unique Special Provisions are intended for a single use on a specific contract for a specific situation on the contract that is not already covered by the Standard Specification or a Special Provision. However, some USPs have been utilized quite frequently on numerous contracts, and have become somewhat “standard”.

PROPOSED SOLUTION: The proposed solution for this USP is to convert it to a Recurring Special Provision in order to expedite the process of implementing this Special Provision into future contracts, while eliminating the need for further review.

APPLICABLE STANDARD SPECIFICATIONS: 725.

APPLICABLE STANDARD DRAWINGS:

APPLICABLE DESIGN MANUAL SECTION:

APPLICABLE SECTION OF GIFE:

APPLICABLE RECURRING SPECIAL PROVISIONS:

PAY ITEMS AFFECTED: None

APPLICABLE SUB-COMMITTEE ENDORSEMENT: Scott Trammell, Construction Specifications Engineer, and the USP Review Process, et al.

IF APPROVED AS A RECURRING SPECIAL PROVISION, THE BASIS FOR USE IS: As determined necessary by the Project Designer.

IMPACT ANALYSIS (attach report): Yes

Submitted By: John Wooden

Title: Estimating Administrator

Organization: Contract Administration

Phone Number: 317-233-5743

Date: September 16, 2021

STANDARD SPECIFICATIONS, SPECIAL PROVISIONS AND STANDARD DRAWINGS
REVISION TO SPECIAL PROVISIONS

IMPACT ANALYSIS REPORT CHECKLIST

Explain the business case as to why this item should be presented to the Standards Committee for approval. Answer the following questions with Yes, No or N/A.

Does this item appear in any other specification sections? Yes, several.

Will approval of this item affect the Approved Materials List? No

Will this proposal improve:

Construction costs? Yes

Construction time? Yes

Customer satisfaction? Yes

Congestion/travel time? Yes

Ride quality? N/A

Will this proposal reduce operational costs or maintenance effort? Yes

Will this item improve safety:

For motorists? Yes

For construction workers? Yes

Will this proposal improve quality for:

Construction procedures/processes? Yes

Asset preservation? Yes

Design process? Maybe

Will this change provide the contractor more flexibility? Yes

Will this proposal provide clarification for the Contractor and field personnel? Yes

Can this item improve/reduce the number of potential change orders? Yes

Is this proposal needed for compliance with:

Federal or State regulations? Yes

AASHTO or other design code? N/A

Is this item editorial? No

Provide any further information as to why this proposal should be placed on the Standards Committee meeting Agenda: For ease of use for implementation and to improve the USP Review Process flow capacity.

REVISION TO SPECIAL PROVISIONS

xxx-x-xxx CURED-IN-PLACE PIPE LINER, CIPP (proposed new)

725-x-xxx CURED-IN-PLACE PIPE LINER, CIPP

(Adopted xx-xx-21)

Description

This work shall consist of the fabrication, installation, and curing of a tight-fitting, resin-impregnated fabric, cured-in-place pipe liner, hereinafter referred to as CIPP, into existing circular or deformed pipe structures in accordance with 105.03.

Materials

CIPP shall be in accordance with ASTM D5813, Type III, grade 1, 2, or 3, and shall be UV and abrasion resistant. The manufacturer shall determine the proper grade of the CIPP to be used under the installation and operation conditions that will exist for the location in which the CIPP is to be used. CIPP shall be designed in accordance with ASTM F1216 and appendix X1 for a fully deteriorated condition.

Right of Entry

If the Contractor desires more working room than the right-of-way provides, the Contractor may elect to pursue rights-of-entry from all necessary adjacent property owners in accordance with 107.14. A temporary fence shall be installed as required to prevent encroachment of the public or livestock into the work area. Upon completion of the work, disturbed areas on private property shall be restored in accordance with 107.14.

QC/QA Procedure

A Type A certification in accordance with 916 and a test report in accordance with ASTM D5813, section 7.3 shall be provided for each existing structure to be lined.

An independent laboratory shall test field-cured samples from each CIPP installation. Appropriate documentation for the independent laboratory shall be provided prior to installation of the CIPP. Testing results shall be provided to the Department within seven days of receipt.

At each structure to be lined, two flat plate samples shall be field cured and submitted for testing. The samples shall be taken directly from the wet-out tube, clamped between flat plates and cured in the downstream end of the tube. As an alternative, two restrained end samples may be used for CIPPs installed in pipes between 8 and 18 in. in diameter, or equivalent. The field-cured samples shall be submitted to the laboratory within three days of the completion of the installation.

The field-cured samples shall be conditioned, prepared, and tested in accordance with ASTM D5813. The wall thickness and flexural tests need only be performed on the structural portion of the CIPP only.

Maintenance of Drainage

Drainage shall be maintained during the installation and curing operations in a manner that does not damage adjacent property.

REVISION TO SPECIAL PROVISIONS

xxx-x-xxx CURED-IN-PLACE PIPE LINER, CIPP (proposed new)

Pre-Installation Requirements

Before beginning the CIPP installation operation, three copies of design calculations shall be submitted in accordance with 105.02, and shall certify:

- (a) the proposed CIPP thickness was determined in accordance with ASTM F1216,
- (b) the required curing pressure,
- (c) the proposed waterway opening is as shown on the plans,
- (d) the minimum required temperature for the initial cure,
- (e) the minimum required temperature and duration for the post-cure, and
- (f) the temperature profile and time required for cool down.

The Contractor shall submit a Water Collection Plan to the Engineer for review and acceptance a minimum of 14 days prior to site operations. The plan shall include phasing and implementation of the effluent collection process, storage, accidental spill procedure, transportation and disposal of effluent generated during the curing or washing process. The Contractor shall provide to the Engineer proof of disposal of effluent and documentation from a State authorized facility receiving the effluent. Copies of any test results required by the disposal site shall be submitted to the Engineer. An IC 203 shall be submitted to cover the disposal site, in accordance with 203.08.

Prior to installing the CIPP, a video inspection of the structure shall be performed. This inspection is to identify cavities in the structure that need to be repaired, and the connecting structures that shall be perpetuated. The video shall become the property of the Department. Cavities adjacent to the existing structure shall be filled in accordance with 725.05. Existing jagged edges or other deformities that impact the CIPP operation or function shall be repaired in accordance with the manufacturer's recommended procedures. All foreign material shall be removed from the existing structure in accordance with the ASTM specifications for the installation method and disposed of in accordance with 203.10.

Installation Requirements

The CIPP shall be installed by the inversion method or the pulled-in-place method. Inversion installation of the CIPP liner shall be in accordance with ASTM F1216. Pulled-in-place installation of the CIPP liner shall be in accordance with ASTM F1743.

If the Contractor elects to use polyester resin, all condensate water and all water in contact with the inside or outside of the CIPP

REVISION TO SPECIAL PROVISIONS

xxx-x-xxx CURED-IN-PLACE PIPE LINER, CIPP (proposed new)

during the curing and cleanup process shall be collected. If the Contractor washes the inside of the CIPP after curing has occurred, then that water shall also be collected.

The Contractor shall monitor and record the temperatures during the initial cure, post-cure, and cool down periods. Remote temperature sensors shall be placed between the existing pipe and the liner in the bottom of the existing pipe at locations as directed by the Engineer. A continuous monitoring system utilizing a fiber optic cable sensing system may be used in lieu of individual sensors. The minimum curing time is the sum of the initial and post curing times. Post-curing time shall be added for any deviations from the recommended post-curing temperature levels. A copy of these records shall be provided to the Engineer.

All CIPP installations shall be performed in dry conditions.

Prior to the liner installation, the Contractor shall place an approved impermeable catchment immediately upstream and downstream of the existing pipe. The impermeable catchment shall work in conjunction with cofferdams to create an impermeable basin to trap contaminated effluent. Any spillage of raw resin during the installation shall also be captured.

The liner shall be continuous with no over-laps and leak-free. The Contractor shall ensure there is no loss of impermeability of the inner and outer plastic films or pre-liner during the installation. Any pinholes, gaps and tears in the plastic film or pre-liner shall be properly repaired before proceeding with the liner installation. Where such damaged areas cannot be repaired, the Contractor shall promptly replace the impermeable plastic films or pre-liner before proceeding with the installation. Cofferdams shall remain in place until wastewater collection processes are complete and secured.

Cured CIPP shall be inspected and videotaped for workmanship. Defects in workmanship as defined in ASTM D5813 section 6.2 shall be repaired or the CIPP shall be replaced so it meets the requirements of these specifications. The repaired or replaced CIPP shall be re-videotaped. The video tape shall become the property of the Department.

The installed CIPP shall be tested for delamination in accordance with the appropriate ASTM specification. The cured CIPP shall be cut within 6 in. of the ends of the existing structure. Where beveled inlets are required, the details shown on the plans shall be followed. Existing connections, including underdrains or another pipe structure, to the structure that was lined shall be perpetuated through the CIPP.

The CIPP shall be permanently marked with a stainless-steel label with a minimum thickness of 0.080 in. located above the structure low water elevation and within 6 in. of the structure end. The information shown on the label shall be at least 1/2 in. tall and shall include the month and year of installation, the CIPP source, and the ASTM material specifications.

REVISION TO SPECIAL PROVISIONS

xxx-x-xxx CURED-IN-PLACE PIPE LINER, CIPP (proposed new)

If the existing pipe or other objects not designated for removal are damaged while performing this work, it shall be considered unauthorized work and shall be repaired or replaced in accordance with 105.11.

There will be no payment for the installation or removal of any liner that cannot be successfully installed due to the condition of the existing pipe.

APPROVED MINUTES

COMMENTS AND ACTION

xxx-x-xxx CURED-IN-PLACE PIPE LINER, CIPP

DISCUSSION:

Mr. Wooden introduced and presented this item stating that Unique Special Provisions are intended for a single use on a specific contract for a specific situation on the contract that is not already covered by the Standard Specification or a Special Provision. However, some USPs have been utilized quite frequently on numerous contracts, and have become somewhat “standard”.

The proposed solution for this USP is to convert it to a Recurring Special Provision in order to expedite the process of implementing this Special Provision into future contracts, while eliminating the need for further review.

There were no questions or comments, and this item passed as submitted.

Motion: Mr. Wooden Second: Mr. Pelz Ayes: 10 Nays: 0 FHWA Approval: YES	Action: <input checked="" type="checkbox"/> Passed as Submitted <input type="checkbox"/> Passed as Revised <input type="checkbox"/> Withdrawn
Standard Specifications Sections referenced and/or affected: 725 begin pg 807.	<input type="checkbox"/> 2024 Standard Specifications <input checked="" type="checkbox"/> Revise Pay Items List
Recurring Special Provision references in: (proposed new)	<input checked="" type="checkbox"/> Create RSP (No. <u>725-R-741</u>) Effective: <u>March 1, 2022</u> RSP Sunset Date:
Standard Drawing affected:	<input type="checkbox"/> Revise RSP (No. __) Effective:
Design Manual Sections affected:	RSP Sunset Date:
GIFE Sections cross-references:	<input type="checkbox"/> Standard Drawing Effective: <input type="checkbox"/> Create RPD (No. __) Effective: <input type="checkbox"/> GIFE Update <input type="checkbox"/> Frequency Manual Update <input checked="" type="checkbox"/> SiteManager Update

STANDARD SPECIFICATIONS, SPECIAL PROVISIONS AND STANDARD DRAWINGS
REVISION TO SPECIAL PROVISIONS

PROPOSAL TO THE STANDARDS COMMITTEE

PROBLEM(S) ENCOUNTERED: Unique Special Provisions are intended for a single use on a specific contract for a specific situation on the contract that is not already covered by the Standard Specification or a Special Provision. However, some USPs have been utilized quite frequently on numerous contracts, and have become somewhat “standard”.

PROPOSED SOLUTION: The proposed solution for this USP is to convert it to a Recurring Special Provision in order to expedite the process of implementing this Special Provision into future contracts, while eliminating the need for further review.

APPLICABLE STANDARD SPECIFICATIONS: 714, 717, and 723.

APPLICABLE STANDARD DRAWINGS:

APPLICABLE DESIGN MANUAL SECTION:

APPLICABLE SECTION OF GIFE:

APPLICABLE RECURRING SPECIAL PROVISIONS:

PAY ITEMS AFFECTED: None

APPLICABLE SUB-COMMITTEE ENDORSEMENT: Scott Trammell, Construction Specifications Engineer, and the USP Review Process, et al.

IF APPROVED AS A RECURRING SPECIAL PROVISION, THE BASIS FOR USE IS: As determined necessary by the Project Designer.

IMPACT ANALYSIS (attach report): Yes

Submitted By: John Wooden

Title: Estimating Administrator

Organization: Contract Administration

Phone Number: 317-233-5743

Date: September 16, 2021

STANDARD SPECIFICATIONS, SPECIAL PROVISIONS AND STANDARD DRAWINGS
REVISION TO SPECIAL PROVISIONS

IMPACT ANALYSIS REPORT CHECKLIST

Explain the business case as to why this item should be presented to the Standards Committee for approval. Answer the following questions with Yes, No or N/A.

Does this item appear in any other specification sections? Yes, several.

Will approval of this item affect the Approved Materials List? No

Will this proposal improve:

Construction costs? Yes

Construction time? Yes

Customer satisfaction? Yes

Congestion/travel time? Yes

Ride quality? N/A

Will this proposal reduce operational costs or maintenance effort? Yes

Will this item improve safety:

For motorists? Yes

For construction workers? Yes

Will this proposal improve quality for:

Construction procedures/processes? Yes

Asset preservation? Yes

Design process? Maybe

Will this change provide the contractor more flexibility? Yes

Will this proposal provide clarification for the Contractor and field personnel? Yes

Can this item improve/reduce the number of potential change orders? Yes

Is this proposal needed for compliance with:

Federal or State regulations? Yes

AASHTO or other design code? N/A

Is this item editorial? No

Provide any further information as to why this proposal should be placed on the Standards Committee meeting Agenda: For ease of use for implementation and to improve the USP Review Process flow capacity.

REVISION TO SPECIAL PROVISIONS

xxx-x-xxx HEADWALLS, WINGWALLS, AND FOOTINGS CONSTRUCTION ON AN
EXISTING STRUCTURE (proposed new)

xxx-x-xxx HEADWALLS, WINGWALLS, AND FOOTINGS CONSTRUCTION ON AN
EXISTING STRUCTURE

(Adopted xx-xx-21)

Description

This work shall consist of the design and construction of cast-in-place or precast concrete headwalls, wingwalls, and footings on an existing structure, in accordance with 105.03.

Materials

Materials shall be in accordance with 714.02 and 711.02.

Concrete shall be class A for headwalls and wingwalls, and class B for footings, in accordance with 702.02.

Construction Requirements

The design of the headwalls, wingwalls and footings shall be the responsibility of the Contractor and shall be in accordance with 714.04(b). The working drawings shall include all details, dimensions, and quantities necessary to construct the headwalls, wingwalls and footings. Design calculations, in accordance with 714.04, shall be submitted with the working drawings.

The headwalls, wingwalls and footings shall be constructed in accordance with the applicable portions of 714.

Reinforcement and stud shear connectors shall be placed as shown on the approved working drawings.

Placement and finishing of the concrete shall be in accordance with 702, unless otherwise noted.

Method of Measurement

The design and construction of the headwalls, wingwalls and footings will be measured in accordance with 702.27. Stud shear connectors will be measured in accordance with 711.3272.

Basis of Payment

The construction of inlet and outlet headwalls, wingwalls and footings, including but not limited to, formwork, materials, placement, stripping of formwork, and finishing will be paid for in accordance with 702.28 as Concrete A Substructure. Stud shear connectors will be paid for in accordance with 711.3373.

The cost of the clearing debris, excavation, design, working drawings, materials, installation, and all necessary incidentals shall be included in the cost of the pay items.

Reinforcing bars will not be paid for directly but shall be included in the cost of the pay items.

Damage made to the host pipe or structure during the headwall,

REVISION TO SPECIAL PROVISIONS

xxx-x-xxx HEADWALLS, WINGWALLS, AND FOOTINGS CONSTRUCTION ON AN
EXISTING STRUCTURE (proposed new)

wingwall or footing construction shall be repaired at no additional cost
to the Department.

APPROVED MINUTES

COMMENTS AND ACTION

xxx-x-xxx HEADWALLS, WINGWALLS, AND FOOTINGS CONSTRUCTION ON AN EXISTING STRUCTURE

DISCUSSION:

Mr. Wooden introduced and presented this item stating that Unique Special Provisions are intended for a single use on a specific contract for a specific situation on the contract that is not already covered by the Standard Specification or a Special Provision. However, some USPs have been utilized quite frequently on numerous contracts, and have become somewhat “standard”.

The proposed solution for this USP is to convert it to a Recurring Special Provision in order to expedite the process of implementing this Special Provision into future contracts, while eliminating the need for further review.

Mr. White suggested including the design calcs with the drawings, and that added language is as shown.

Mr. Wooden revised his motion, and this item passed as revised.

<p>Motion: Mr. Wooden Second: Mr. Pelz Ayes: 10 Nays: 0 FHWA Approval: YES</p>	<p>Action: <input type="checkbox"/> Passed as Submitted <input checked="" type="checkbox"/> Passed as Revised <input type="checkbox"/> Withdrawn</p>
<p>Standard Specifications Sections referenced and/or affected:</p>	<p><input type="checkbox"/> 2024 Standard Specifications</p>
<p style="text-align: center;">various</p>	<p><input type="checkbox"/> Revise Pay Items List</p>
<p>Recurring Special Provision references in: (proposed new)</p>	<p><input checked="" type="checkbox"/> Create RSP (No. <u>702-R-743</u> Effective: <u>March 1, 2022</u> RSP Sunset Date:</p>
<p>Standard Drawing affected:</p>	<p><input type="checkbox"/> Revise RSP (No. __) Effective:</p>
<p>Design Manual Sections affected:</p>	<p>RSP Sunset Date:</p>
<p>GIFE Sections cross-references:</p>	<p><input type="checkbox"/> Standard Drawing Effective:</p>
	<p><input type="checkbox"/> Create RPD (No. __) Effective:</p>
	<p><input type="checkbox"/> GIFE Update</p>
	<p><input type="checkbox"/> Frequency Manual Update <input type="checkbox"/> SiteManager Update</p>

STANDARD SPECIFICATIONS, SPECIAL PROVISIONS AND STANDARD DRAWINGS
REVISION TO SPECIAL PROVISIONS

PROPOSAL TO THE STANDARDS COMMITTEE

PROBLEM(S) ENCOUNTERED: Unique Special Provisions are intended for a single use on a specific contract for a specific situation on the contract that is not already covered by the Standard Specification or a Special Provision. However, some USPs have been utilized quite frequently on numerous contracts, and have become somewhat “standard”.

PROPOSED SOLUTION: The proposed solution for this USP is to convert it to a Recurring Special Provision in order to expedite the process of implementing this Special Provision into future contracts, while eliminating the need for further review.

APPLICABLE STANDARD SPECIFICATIONS: 107.

APPLICABLE STANDARD DRAWINGS:

APPLICABLE DESIGN MANUAL SECTION:

APPLICABLE SECTION OF GIFE:

APPLICABLE RECURRING SPECIAL PROVISIONS:

PAY ITEMS AFFECTED: None

APPLICABLE SUB-COMMITTEE ENDORSEMENT: Scott Trammell, Construction Specifications Engineer, and the USP Review Process, et al.

IF APPROVED AS A RECURRING SPECIAL PROVISION, THE BASIS FOR USE IS: As determined necessary by the Project Designer.

IMPACT ANALYSIS (attach report): Yes

Submitted By: John Wooden

Title: Estimating Administrator

Organization: Contract Administration

Phone Number: 317-233-5743

Date: September 16, 2021

STANDARD SPECIFICATIONS, SPECIAL PROVISIONS AND STANDARD DRAWINGS
REVISION TO SPECIAL PROVISIONS

IMPACT ANALYSIS REPORT CHECKLIST

Explain the business case as to why this item should be presented to the Standards Committee for approval. Answer the following questions with Yes, No or N/A.

Does this item appear in any other specification sections? Yes, several.

Will approval of this item affect the Approved Materials List? No

Will this proposal improve:

Construction costs? Yes

Construction time? Yes

Customer satisfaction? Yes

Congestion/travel time? Yes

Ride quality? N/A

Will this proposal reduce operational costs or maintenance effort? Yes

Will this item improve safety:

For motorists? Yes

For construction workers? Yes

Will this proposal improve quality for:

Construction procedures/processes? Yes

Asset preservation? Yes

Design process? Maybe

Will this change provide the contractor more flexibility? Yes

Will this proposal provide clarification for the Contractor and field personnel? Yes

Can this item improve/reduce the number of potential change orders? Yes

Is this proposal needed for compliance with:

Federal or State regulations? Yes

AASHTO or other design code? N/A

Is this item editorial? No

Provide any further information as to why this proposal should be placed on the Standards Committee meeting Agenda: For ease of use for implementation and to improve the USP Review Process flow capacity.

REVISION TO SPECIAL PROVISIONS

107-x-xxx MIGRATORY BIRD PROTECTION (proposed new)

107-x-xxx MIGRATORY BIRD PROTECTION

(Adopted xx-xx-21)

Description

This work shall consist of protecting migratory bird species as required by the Migratory Bird Treaty Act, MBTA, in accordance with 105.03.

Materials

Materials shall be as required and as described herein.

Construction Requirements

The structures may, or may not, have shown evidence of use, such as nests, by a bird species protected under the MBTA during previous inspections. Every effort shall be made by the Contractor not to disturb any nests with eggs or young.

Intentional taking of migratory birds or nests with eggs or young without a federal permit is prohibited by the Migratory Bird Treaty Act, 16 U.S.C. 703-712.

During the period between May 1 and September 7, bridge work on structures with migratory birds will be allowed provided the procedure below is implemented:

No special action is necessary by the Contractor for bridge work performed entirely on the deck as long as the Contractor shall not require access to areas where birds are nesting and contract work will not result in the disturbance of nesting adults, or to their eggs or young. Disturbance is any activity that would result in reproductive failures or the killing of eggs or young.

For bridge structures that have previous or current evidence of use and where the work will be done entirely on the deck that may result in perforation of the deck or create strong vibrations that could potentially dislodge nests beneath the deck or that requires activity above and below the deck to include removal shall require that the Contractor use exclusionary devices to deter birds from nesting beneath the deck prior to start of work. If birds are present, the Contractor shall determine the status of the birds, their nests, and young and shall take any and all actions necessary to meet the requirements of the MBTA.

For bridge work performed from September 8 to April 30, birds are normally not nesting; therefore, no special actions by the Contractor are necessary after an inspection is conducted to determine that no birds are present.

Avoidance and Minimization Measures

Measures designed to avoid and minimize impacts to migratory birds nesting on structures shall be implemented prior to April 30 and be maintained throughout the nesting season. The Contractor shall be

REVISION TO SPECIAL PROVISIONS

107-x-xxx MIGRATORY BIRD PROTECTION (proposed new)

responsible for developing a project specific avoidance and minimization plan that shall be as approved by the Engineer. Avoidance and minimization measures shall include, but shall not be limited to:

After inspection and confirmation that no active nests with eggs or young are present, the Contractor shall remove existing nests and other nesting debris from the bridge girders or other surfaces that will be impacted by the project.

After nest removal, exclusion devices shall be installed on the structure, especially if the start of construction will be delayed after April 30. Exclusion devices may include plastic sheeting, canvas, burlap or other material to block access to the underside of bridges and exterior girders. Ledge protectors, such as coil, pin and wire, can be placed on structures to prevent nest building where appropriate. The use of weather resistant polypropylene netting with 1/4 in. or smaller openings is also an option but is not recommended since it can trap adult birds.

After nest removal, hazing or harassment devices using sight or sound to scare the birds away may be installed on the structure. Materials may include mylar flagging and auditory speakers. Other sensory deterrents such as active construction, predator models, scare balloons and sonic devices may also be used.

The Contractor shall inspect the underside of the existing structure on a routine basis to ensure that nests are removed prior to egg laying and that exclusion devices that have been damaged are repaired. If eggs or young are present, construction activity that may impact those nests shall not occur and the Department's Office of Environmental Services shall be contacted. No additional contract time will be granted if eggs or young are found.

If approved by the Engineer, the Contractor shall consider not removing nests that are near, but not in, the immediate work area. The nests may also be screened from construction to prevent impacts. Work may continue if the active nests will not be destroyed and if parent birds will not be precluded from tending their nests to the extent that eggs or young are negatively impacted.

Status of Birds and Nests

If birds penetrate the barrier or nest building has commenced, the Contractor shall determine how birds are entering the underside of the bridge and adjust or repair the barrier to prevent further access. If nest building or repair of existing nests has begun, but no eggs or young are present in the nests based upon visual inspection of the nest and activity of the adults, the Contractor shall remove the nests.

Every effort shall be made by the Contractor not to disturb any nests with eggs or young. If active nests with eggs or young are found that would be affected by construction activities, work shall be delayed until an evaluation of nesting status and avoidance and minimization measures implemented or the birds fledge from the nest.

REVISION TO SPECIAL PROVISIONS

107-x-xxx MIGRATORY BIRD PROTECTION (proposed new)

Method of Measurement

Monitoring the structures, removal of nests and the furnishing, installation, and removal of bird deterrents, and all other activities associated with the migratory bird protection as described herein will not be measured for payment.

Basis of Payment

All costs for determining the need for, the placing of deterrents and all costs associated with conducting work in compliance with the Migratory Bird Treaty Act as stated herein will not be paid for separately but shall be included in the cost of other items.

APPROVED MINUTES

COMMENTS AND ACTION

107-x-xxx MIGRATORY BIRD PROTECTION

DISCUSSION:

Mr. Wooden introduced and presented this item stating that Unique Special Provisions are intended for a single use on a specific contract for a specific situation on the contract that is not already covered by the Standard Specification or a Special Provision. However, some USPs have been utilized quite frequently on numerous contracts, and have become somewhat "standard".

The proposed solution for this USP is to convert it to a Recurring Special Provision in order to expedite the process of implementing this Special Provision into future contracts, while eliminating the need for further review.

Discussion ensued as to the payment method and it was decided to leave the language as-is in order to avoid any potential issues.

There was no further discussion and this item passed as submitted.

<p>Motion: Mr. Wooden Second: Mr. Pelz Ayes: 10 Nays: 0 FHWA Approval: YES</p>	<p>Action: <input checked="" type="checkbox"/> Passed as Submitted <input type="checkbox"/> Passed as Revised <input type="checkbox"/> Withdrawn</p>
<p>Standard Specifications Sections referenced and/or affected:</p>	<p><input type="checkbox"/> 2024 Standard Specifications</p>
<p>107 pg 67 - 83.</p>	<p><input type="checkbox"/> Revise Pay Items List</p>
<p>Recurring Special Provision references in: (proposed new)</p>	<p><input checked="" type="checkbox"/> Create RSP (No. <u>107-C-273</u>) Effective: <u>March 1, 2022</u> RSP Sunset Date:</p>
<p>Standard Drawing affected: NONE</p>	<p><input type="checkbox"/> Revise RSP (No. __) Effective: RSP Sunset Date:</p>
<p>Design Manual Sections affected:</p>	<p><input type="checkbox"/> Standard Drawing Effective:</p>
<p>GIFE Sections cross-references:</p>	<p><input type="checkbox"/> Create RPD (No. __) Effective:</p>
	<p><input type="checkbox"/> GIFE Update <input type="checkbox"/> Frequency Manual Update <input type="checkbox"/> SiteManager Update</p>

STANDARD SPECIFICATIONS, SPECIAL PROVISIONS AND STANDARD DRAWINGS
REVISION TO SPECIAL PROVISIONS

PROPOSAL TO THE STANDARDS COMMITTEE

PROBLEM(S) ENCOUNTERED: Unique Special Provisions are intended for a single use on a specific contract for a specific situation on the contract that is not already covered by the Standard Specification or a Special Provision. However, some USPs have been utilized quite frequently on numerous contracts, and have become somewhat “standard”.

PROPOSED SOLUTION: The proposed solution for this USP is to convert it to a Recurring Special Provision in order to expedite the process of implementing this Special Provision into future contracts, while eliminating the need for further review.

APPLICABLE STANDARD SPECIFICATIONS: 205, 206, and 211.

APPLICABLE STANDARD DRAWINGS:

APPLICABLE DESIGN MANUAL SECTION:

APPLICABLE SECTION OF GIFE:

APPLICABLE RECURRING SPECIAL PROVISIONS:

PAY ITEMS AFFECTED: None

APPLICABLE SUB-COMMITTEE ENDORSEMENT: Scott Trammell, Construction Specifications Engineer, and the USP Review Process, et al.

IF APPROVED AS A RECURRING SPECIAL PROVISION, THE BASIS FOR USE IS: As determined necessary by the Project Designer.

IMPACT ANALYSIS (attach report): Yes

Submitted By: John Wooden

Title: Estimating Administrator

Organization: Contract Administration

Phone Number: 317-233-5743

Date: September 16, 2021

STANDARD SPECIFICATIONS, SPECIAL PROVISIONS AND STANDARD DRAWINGS
REVISION TO SPECIAL PROVISIONS

IMPACT ANALYSIS REPORT CHECKLIST

Explain the business case as to why this item should be presented to the Standards Committee for approval. Answer the following questions with Yes, No or N/A.

Does this item appear in any other specification sections? Yes, several.

Will approval of this item affect the Approved Materials List? No

Will this proposal improve:

Construction costs? Yes

Construction time? Yes

Customer satisfaction? Yes

Congestion/travel time? Yes

Ride quality? N/A

Will this proposal reduce operational costs or maintenance effort? Yes

Will this item improve safety:

For motorists? Yes

For construction workers? Yes

Will this proposal improve quality for:

Construction procedures/processes? Yes

Asset preservation? Yes

Design process? Maybe

Will this change provide the contractor more flexibility? Yes

Will this proposal provide clarification for the Contractor and field personnel? Yes

Can this item improve/reduce the number of potential change orders? Yes

Is this proposal needed for compliance with:

Federal or State regulations? Yes

AASHTO or other design code? N/A

Is this item editorial? No

Provide any further information as to why this proposal should be placed on the Standards Committee meeting Agenda: For ease of use for implementation and to improve the USP Review Process flow capacity.

REVISION TO SPECIAL PROVISIONS

xxx-x-xxx PUMP AROUND (proposed new)

206-R-xxx PUMP AROUND

(Adopted xx-xx-21)

Description

This work shall consist of furnishing, installing, and maintaining a pump around in accordance with 105.03.

The pump around shall be part of the temporary stormwater control plan and shall be constructed with the other temporary stormwater control measures in accordance with 205.

Materials

Materials shall be in accordance with 205.02.

The pump around dikes shall be constructed of non-erodable materials. Sandbag dikes shall be covered with impervious plastic sheeting, placed on the open channel side of the dikes. Sheet piling shall be watertight. Pump around and dewatering hoses shall be made of impervious material.

Construction Requirements

The Contractor may use an alternate method for the channel work as shown on the plans, pending the approval of the Engineer. If an alternate method is proposed, the Contractor shall make the appropriate permit application or amendment.

Traversing the channel reach with equipment within the work area where no work is proposed shall be avoided. If equipment is required to traverse such a reach for access to another area, timber mats or similar measures shall be used to minimize disturbance to the channel. A temporary channel crossing shall be used only when necessary and as approved.

The stormwater control measures adjacent to the channel area shall be installed before construction on the pump around can begin. All work shall stay within the construction limits. Disturbance within that area shall be minimized.

Work shall not be conducted during rain events.

Pump Around

The pump around shall be in accordance with the following:

Dewatering of the channel shall be performed by using a mechanical pump. The intake suction hose shall be floated as long as possible to prevent the pump from pulling sediment from the bottom of the pooled area.

Sandbag dikes shall be installed at the upstream and downstream ends of the work area as shown in the details, and the channel flow shall be pumped around the work area. The pump shall discharge onto a stable velocity dissipater consisting of riprap or sandbags or other approved medium.

REVISION TO SPECIAL PROVISIONS

xxx-x-xxx PUMP AROUND (proposed new)

Water trapped within the work area shall be pumped to a sediment filtering measure such as a dewatering basin, ~~sediment~~ filter bag, or other approved device. The sediment filtering measure shall be located such that the water drains back into a stabilized area and into the channel below the downstream dike.

Dewatering Filter Bag

A dewatering filter bag shall be securely connected to the end of the discharge hose.

The dewatering *filter* bag shall be a single-use or reusable type of bag and shall be constructed of non-woven, polypropylene geotextile material. The bag shall have the following minimum specifications:

Permittivity - 1.4 sec^{-1}
Grab Tensile - 205 lbs
Weight - 8 oz/sys
Apparent Opening Size - 80 US Sieve.

The dewatering *filter* bag shall be placed on a flat surface and on riprap or sandbags to help increase the flow through the dewatering bag and help dissipate the velocity.

Water shall be pumped from the channeled area at a rate not to exceed the maximum manufacturer's recommended flow rate of the dewatering *filter* bag.

Dewatering *filter* bags shall be placed in a location in which runoff from the bag will pass through additional sediment control measures prior to leaving the site.

Following the completion of the dewatering, the sediment accumulated within the dewatering *filter* bag shall be removed from the bag and placed in an upland area.

Maintenance and Inspection

The diversion measures shall be inspected within 24 hours of each rainfall event and at least once every seven calendar days. The sediment and debris from the channel or upstream clean water dike shall be removed. The dikes shall be repaired as needed. All outlets shall be checked and repaired as needed to prevent washouts. The dewatering filter bag shall be checked and cleaned.

Removal

Pump around shall be removed after construction in the main channel is complete and permanent stormwater control features have been established. Any areas disturbed by the pump around measures shall be returned to their original condition and re-vegetated as needed.

Method of Measurement

Pump around will be measured by the number of units installed, complete in place.

REVISION TO SPECIAL PROVISIONS

xxx-x-xxx PUMP AROUND (proposed new)

Basis of Payment

The acceptable quantities of pump around will be paid for at the contract unit price per each.

Payment will be made under:

Pay Item

Pay Unit Symbol

Pump Around.....EACH

The cost of furnishing all materials, equipment, labor, installation, maintenance, and removal required for dewatering and operation of the temporary pump around shall be included in the cost of pump around.

The cost of temporary channel crossings if required shall be included in the cost of the pump around.

APPROVED MINUTES

COMMENTS AND ACTION

xxx-x-xxx PUMP AROUND

DISCUSSION:

Mr. Wooden introduced and presented this item stating that Unique Special Provisions are intended for a single use on a specific contract for a specific situation on the contract that is not already covered by the Standard Specification or a Special Provision. However, some USPs have been utilized quite frequently on numerous contracts, and have become somewhat “standard”.

The proposed solution for this USP is to convert it to a Recurring Special Provision in order to expedite the process of implementing this Special Provision into future contracts, while eliminating the need for further review. Mr. Wooden proposed to approve this item as revised, as explained below.

Mr. Koch asked if we could be consistent regarding the term used for the dewatering bag, since a sediment bag is another term for filter bag/dewatering filter bag. Mr. Slaymon suggested using the term filter bag. The revisions are as shown highlighted above. Mr. Couch said this is good as revised.

There was no further discussion and this item passed as revised.

Motion: Mr. Wooden Second: Mr. Pelz Ayes: 10 Nays: 0 FHWA Approval: YES	Action: <input type="checkbox"/> Passed as Submitted <input checked="" type="checkbox"/> Passed as Revised <input type="checkbox"/> Withdrawn
Standard Specifications Sections referenced and/or affected: 205, 206, and 211.	<input type="checkbox"/> 2024 Standard Specifications <input checked="" type="checkbox"/> Revise Pay Items List <input checked="" type="checkbox"/> Create RSP (No. <u>206-R-740</u>) Effective: <u>March 1, 2022</u> RSP Sunset Date:
Recurring Special Provision references in: (proposed new)	<input type="checkbox"/> Revise RSP (No. __) Effective: RSP Sunset Date:
Standard Drawing affected:	<input type="checkbox"/> Standard Drawing Effective:
Design Manual Sections affected:	<input type="checkbox"/> Create RPD (No. __) Effective:
GIFE Sections cross-references:	<input type="checkbox"/> GIFE Update <input type="checkbox"/> Frequency Manual Update <input checked="" type="checkbox"/> SiteManager Update